

NBA Game Time • Hoop FX Collegiate • Globetrotters



Service Manual

Innovative Concepts in Entertainment

10123 Main Street, Clarence NY 14031

(716) 759-0360 www.icegame.com

Table of Contents

Safety and Warnings	3
What's included	4
Assembly	5
Skirt Install (Optional)	10
Linking	12
Mega Marquee Install	13
Program Options	17
Mega Marquee Programming	21
Maintenance	22
Trouble Shooting	
Linking Issues?	23
Net Sensor Issues?	26
Net not Moving?	27
Ball gate Issues?	29
Schematics	30 - 31
Diagrams	
Backboard Assembly	32
Podium	33
Cabinet (ball gate and cage)	34
Marquee Hardware	35
Spares	36
Warranty	37

SAFETY AND WARNINGS BEFORE YOU BEGIN

WARNING: WHEN INSTALLING THIS GAME, A GROUNDED A.C. RECEPTACLE MUST BE USED. FAILURE TO DO SO COULD RESULT IN INJURY TO YOURSELF OR OTHERS. FAILURE TO USE A GROUNDED RECEPTACLE COULD ALSO CAUSE IMPROPER GAME OPERATION, OR DAMAGE TO THE ELECTRONICS.

NOTE: THIS GAME IS INTENDED FOR INDOOR USE ONLY.

DO NOT DEFEAT OR REMOVE THE GROUNDING PRONG ON THE POWER CORD FOR THE SAME REASON AS GIVEN ABOVE. USING AN IMPROPERLY GROUNDED GAME COULD VOID YOUR WARRANTY.

HAVE A QUALIFIED ELECTRICIAN CHECK YOUR A.C. RECEPTACLE TO BE SURE THE GROUND IS FUNCTIONING PROPERLY.

THIS GAME IS DESIGNED TO DISSIPATE STATIC ELECTRICITY THROUGH THE GROUNDING PLANE OF THE GAME. IF THE A.C. GROUND DOES NOT WORK, THE GAME COULD DISCHARGE STATIC ELECTRICITY THROUGH THE GAME CIRCUITRY, WHICH COULD CAUSE DAMAGE.

THE POWER SUPPLY IS NOT VOLTAGE ADJUSTABLE. TO OPERATE THE GAME AT VOLTAGES OTHER THAN THOSE IT WAS DESIGNED FOR. PLEASE CONTACT OUR SERVICE DEPARTMENT FOR VOLTAGE CONVERSION INFORMATION.

WARNING

DO NOT remove any of the components on the main board (e.g. compact flash and eproms) while the game is powered on. This may cause permanent damage to the parts and the main board. Removing any main board component part while powered on will void the warranty.

ALWAYS REMOVE POWER TO THE GAME, BEFORE ATTEMPTING ANY SERVICE, UNLESS NEEDED FOR SPECIFIC TESTING. FAILURE TO OBSERVE THIS PRECAUTION COULD RESULT IN SERIOUS INJURY TO YOURSELF OR OTHERS.

THIS GAME IS NOT SUITABLE FOR INSTALLATION IN AN AREA WHERE A WATER JET COULD BE USED.

This appliance is not intended for use by persons (including children) with reduced physical, sensory or mental capabilities, or lack of experience and knowledge, unless they have been given supervision or instruction concerning use of the appliance by a person responsible for their safety. Children should be supervised to ensure that they do not play with the appliance.

AC Power Information

The games main fuse is accessed through the back of the game at the power mod. Above the power cord is a small panel that contains the main fuse.

The value of the fuse for 120 volt users is 4 AMPS at 250Volt type slow blow.

The value of the fuse for 220/230 users is 2.5 AMPS at 250Volt type slow blow.

Fully Disassembled Games - Parts included Page

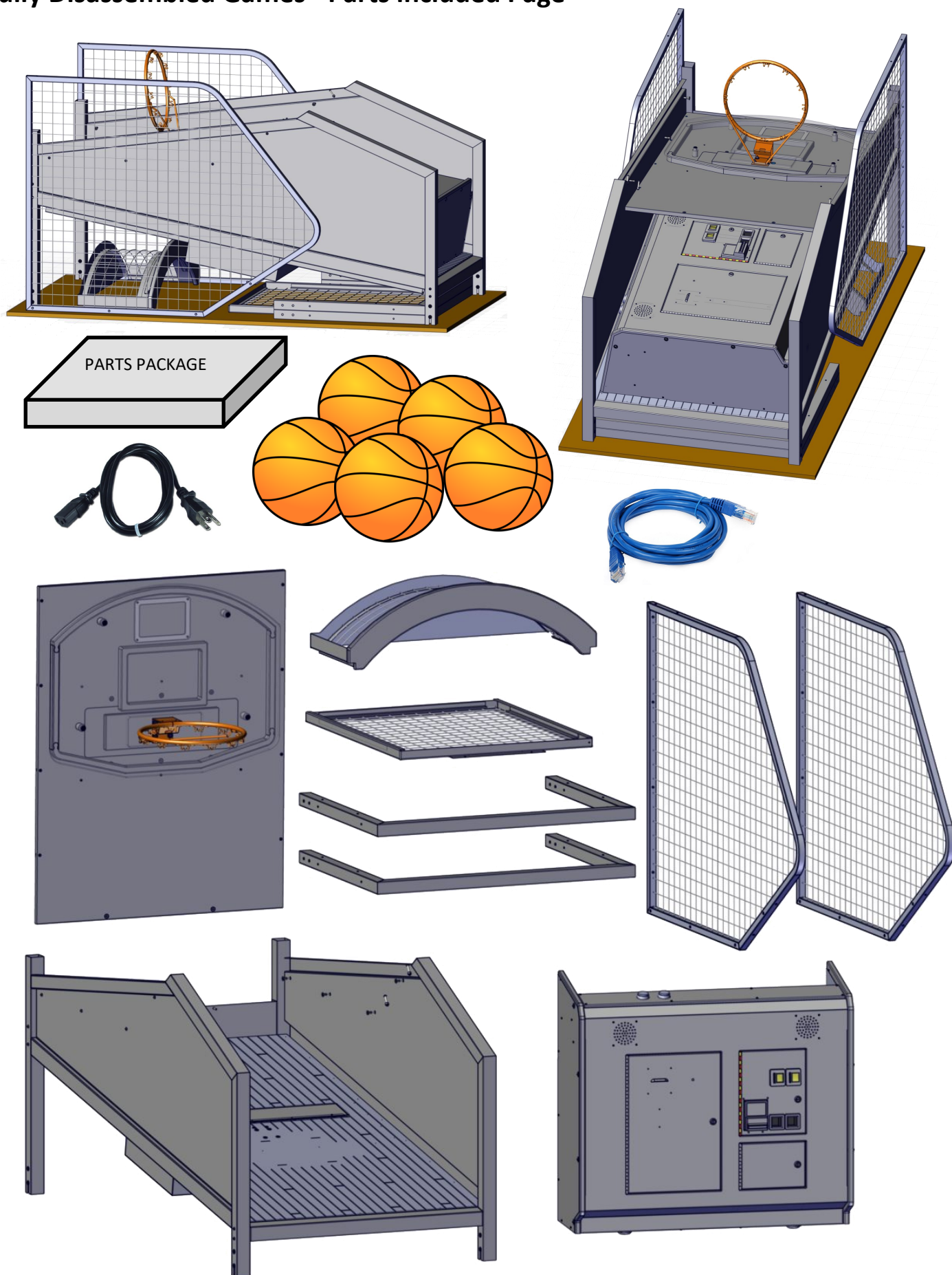

Place two basket balls under the main cabinet. Insert one 6110 insert to one side and one 6110 with 6107 attached to the other side in the middle hole, at the top of one leg (either, they are the same). When tightened a small space will be present between the leg and 6110 nuts. Repeat for other side. Then slide the front leg into the cabinet front until it rests on the AA06110 inserts.

Secure using one 6110 insert to one side and one 6110 with 6107 attached to the other side in the upper hole. Repeat for the other side. REPEAT for the back leg using the same hardware and hole positions.

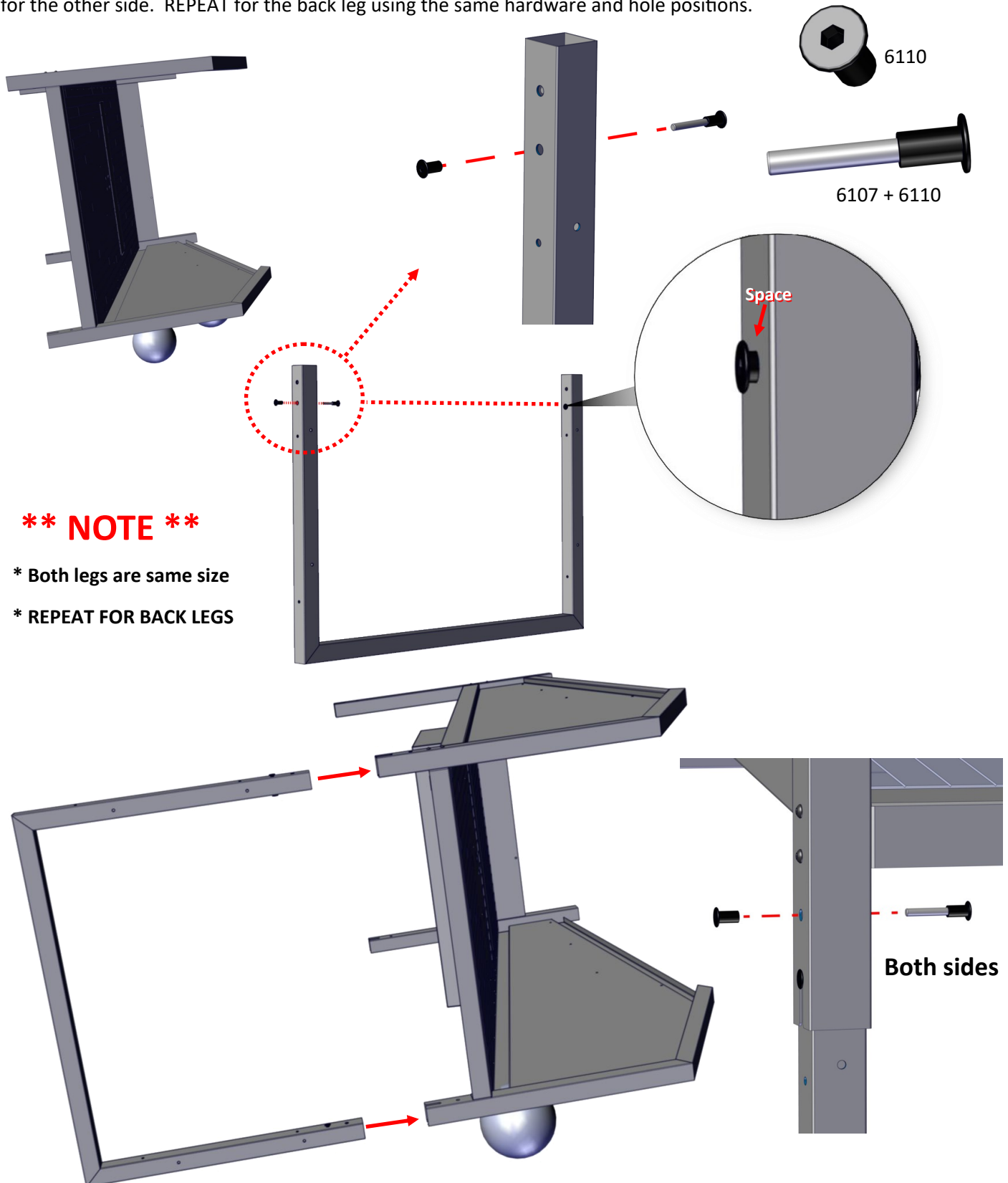

Lift the cabinet back upright. Then position the backboard at the back of the cabinet. Use two 6799 Allen bolts to secure the backboard to the cabinet.

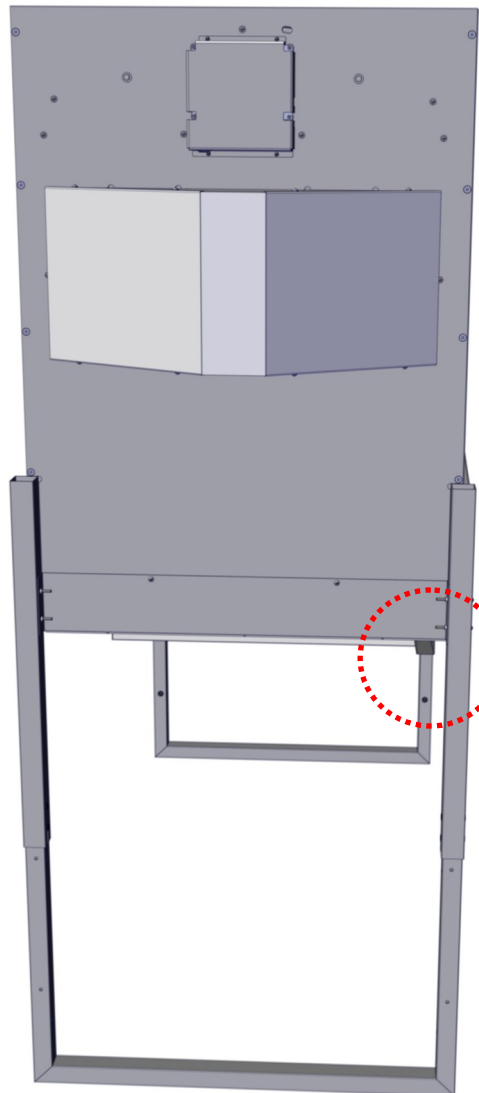
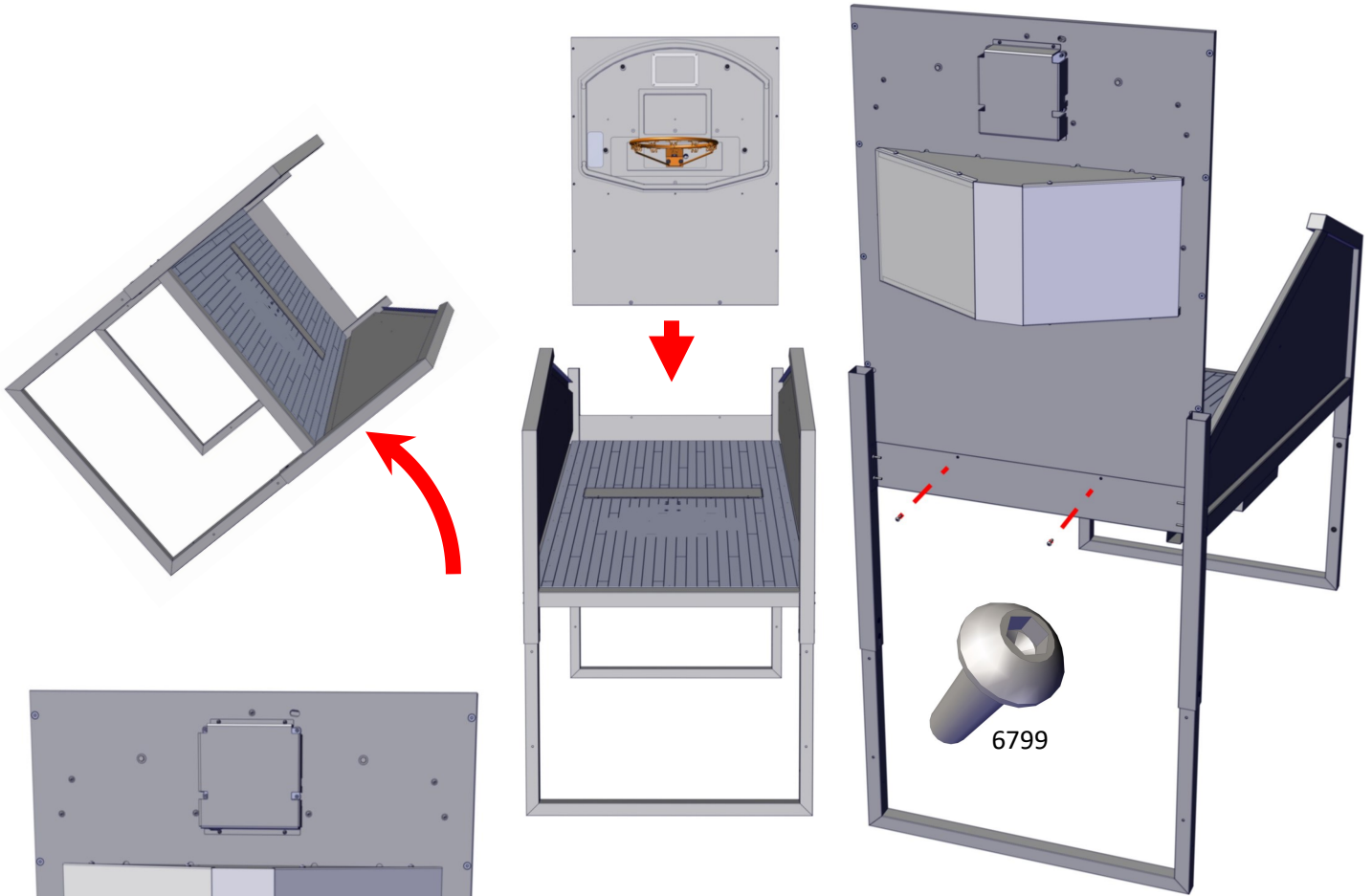

Then connect the two backboard harnesses into the cabinet base.



Lift the left side cage up onto the cabinet. It mounts to the inside of the cabinet. Using four AA6220 bolts and AA6430 washers secure the back of the cage to the backboard.

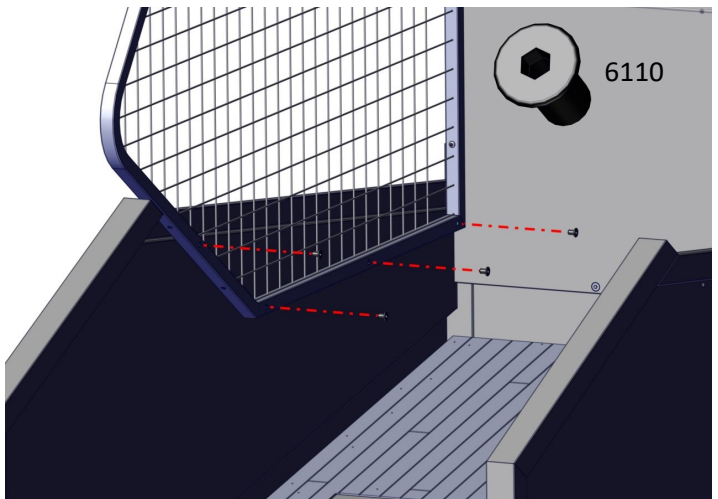
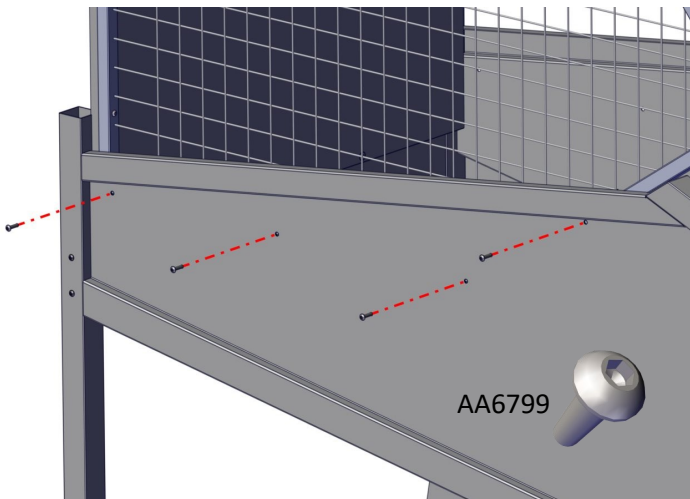
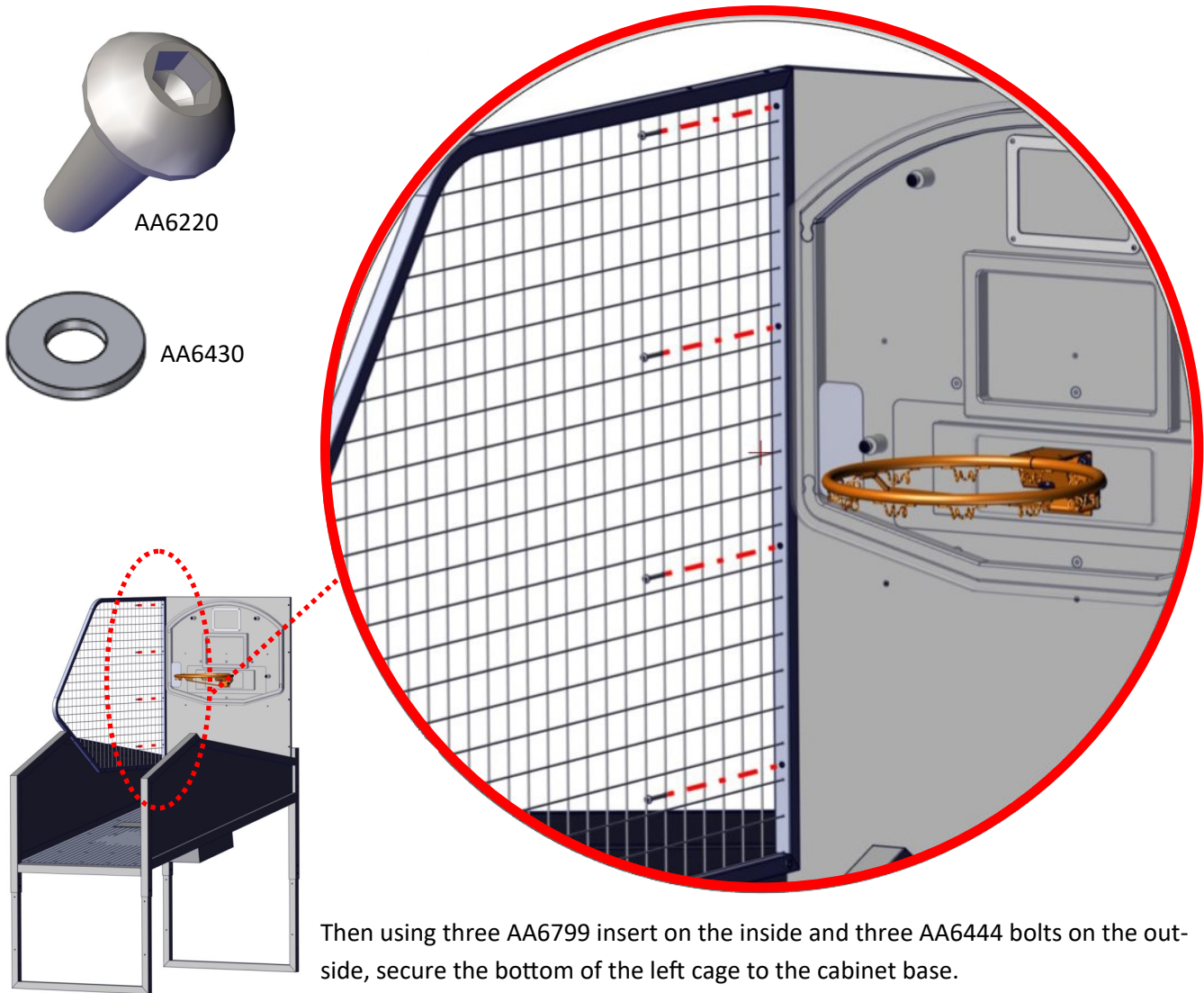

REPEAT FOR THE RIGHT CAGE

Slide the basket ball deflector cage in between the side cages and cabinet base. The bracket goes at the top of the deflector. Attach the deflector cage with four AA6084 bolts from the bottom, NS1073 spring, WF1057, two on each side. Secure with four AA6966 nylon nuts from the bottom, two on each side.

Bracket at bottom even though the picture shows it at top.

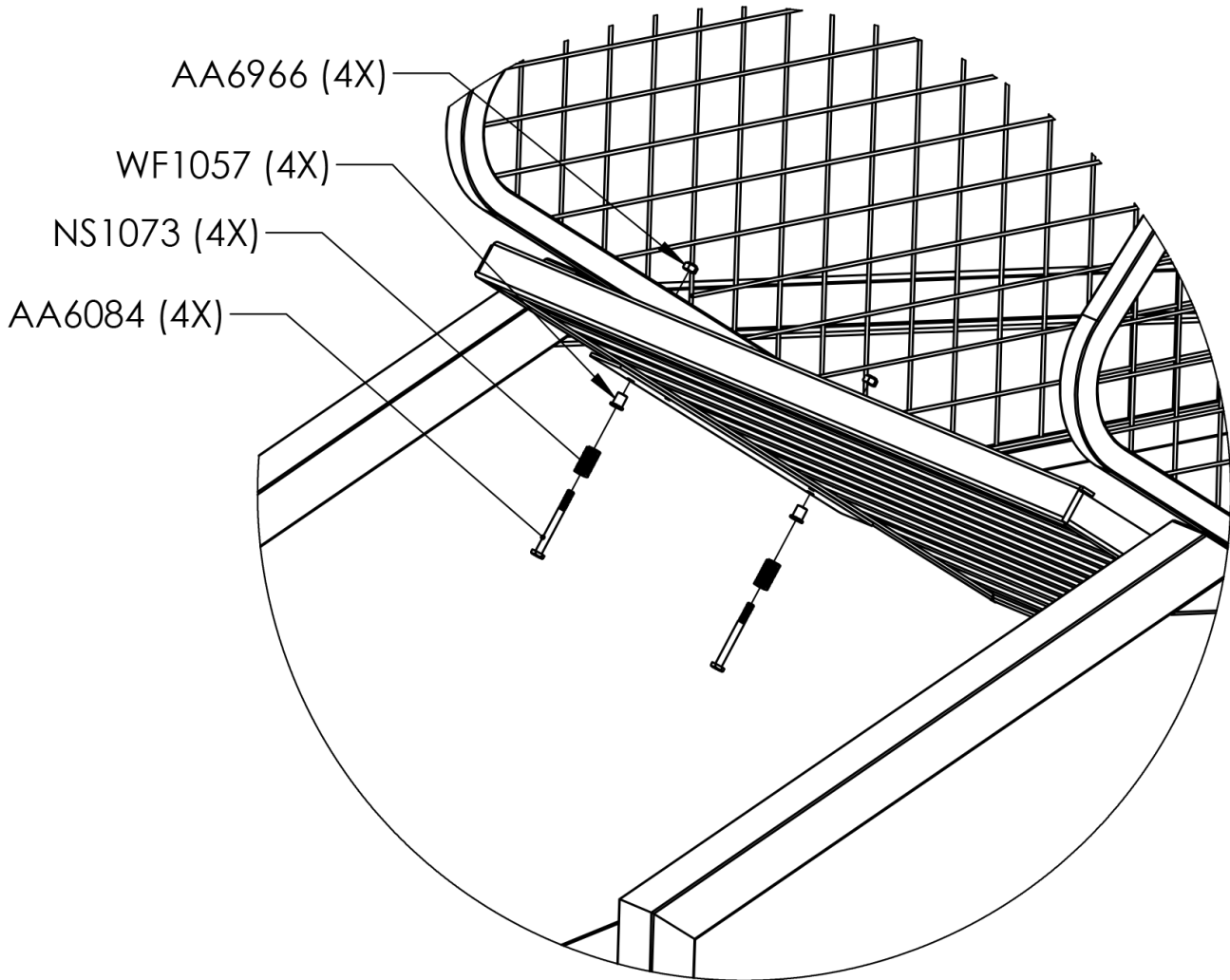
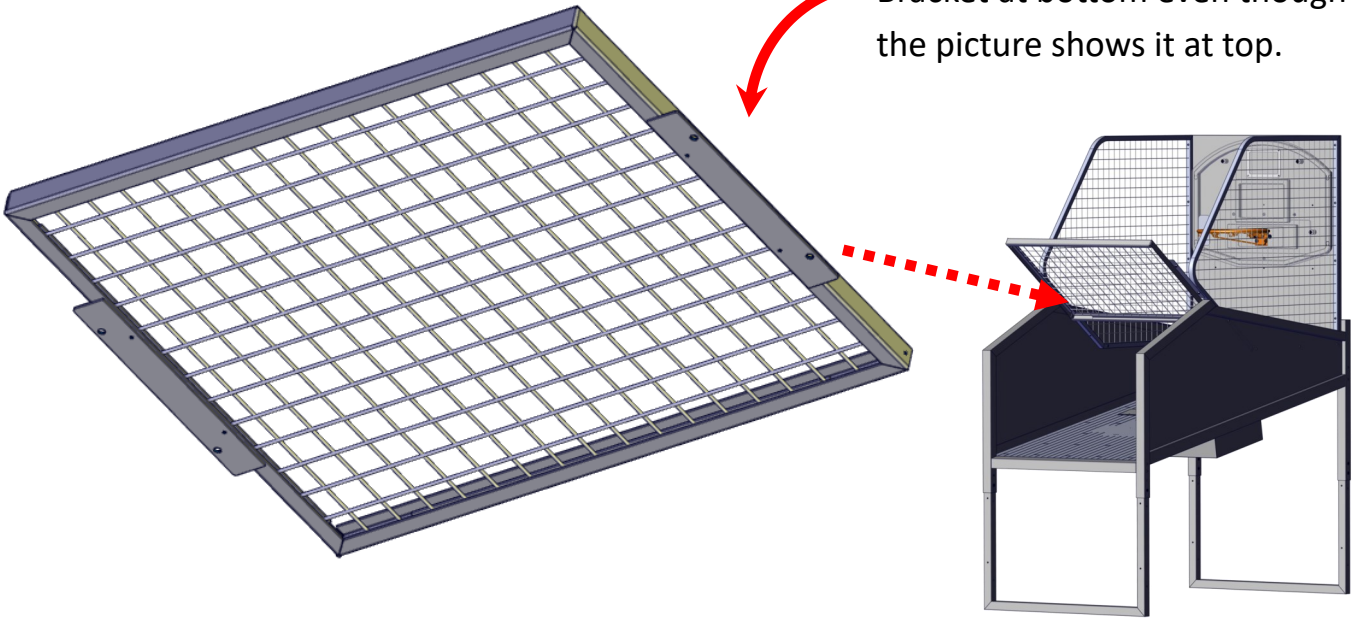

Lift the top cage up onto the cabinet. Using four AA6281 bolts secure the sides of the top cage to the cage sides.

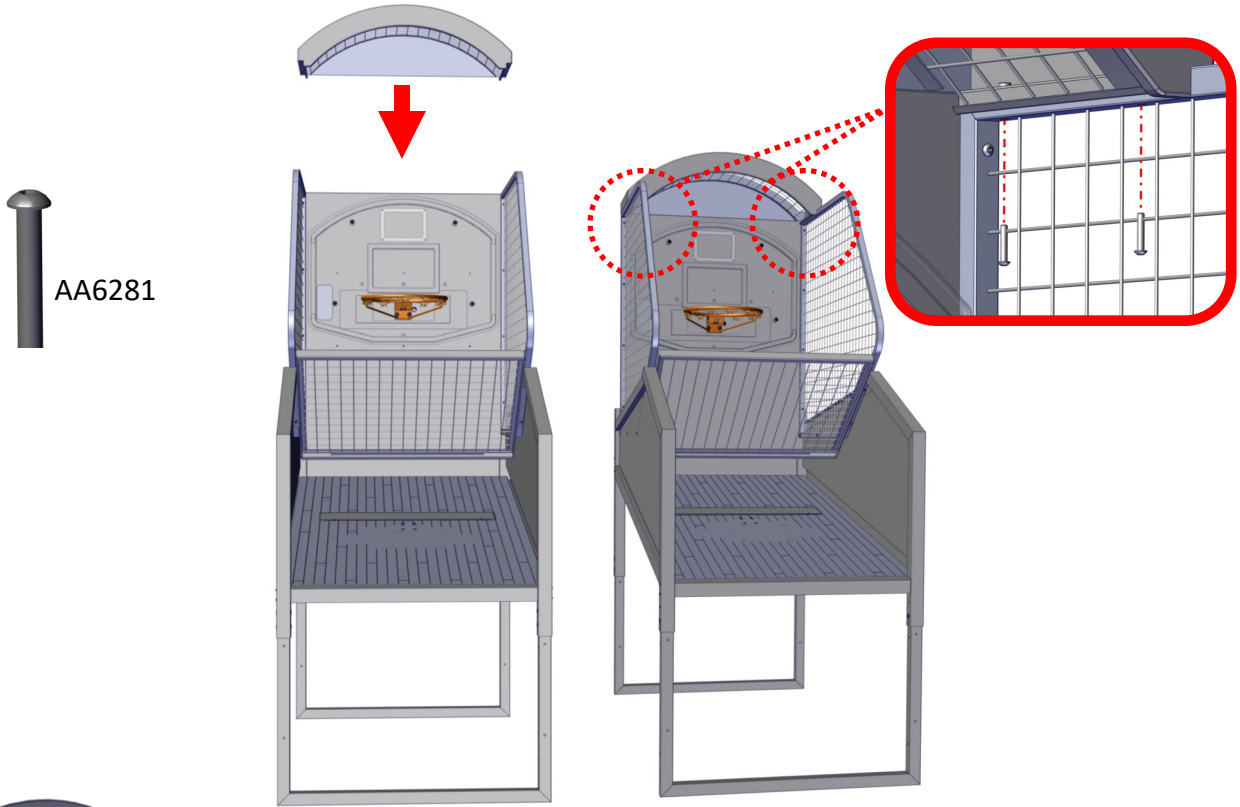

Attach the podium to the front of the cabinet using four 6369 bolts and AA6212 washers.

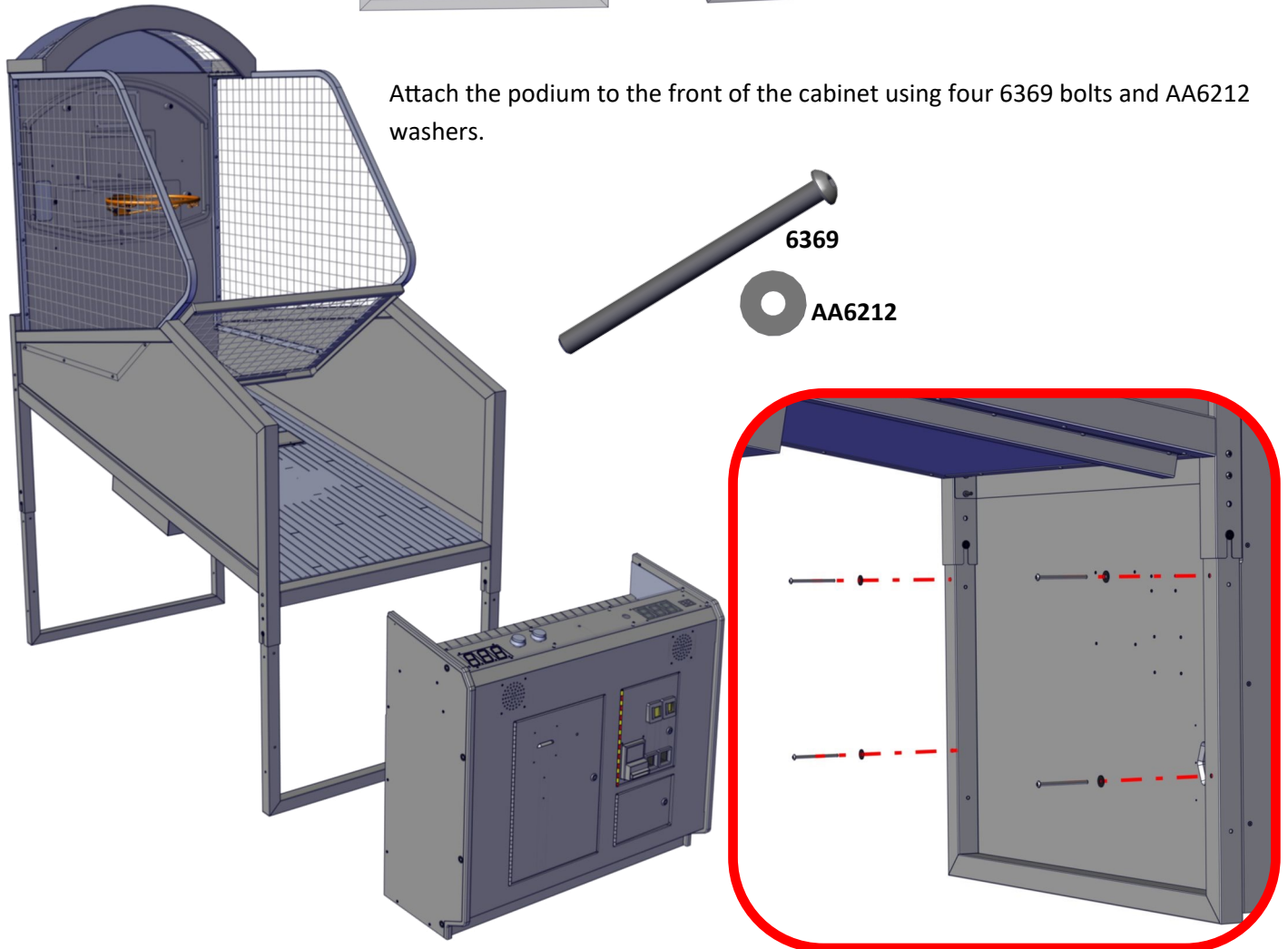

Connect the cabinet base harnesses to the podium harness. There are three in total.

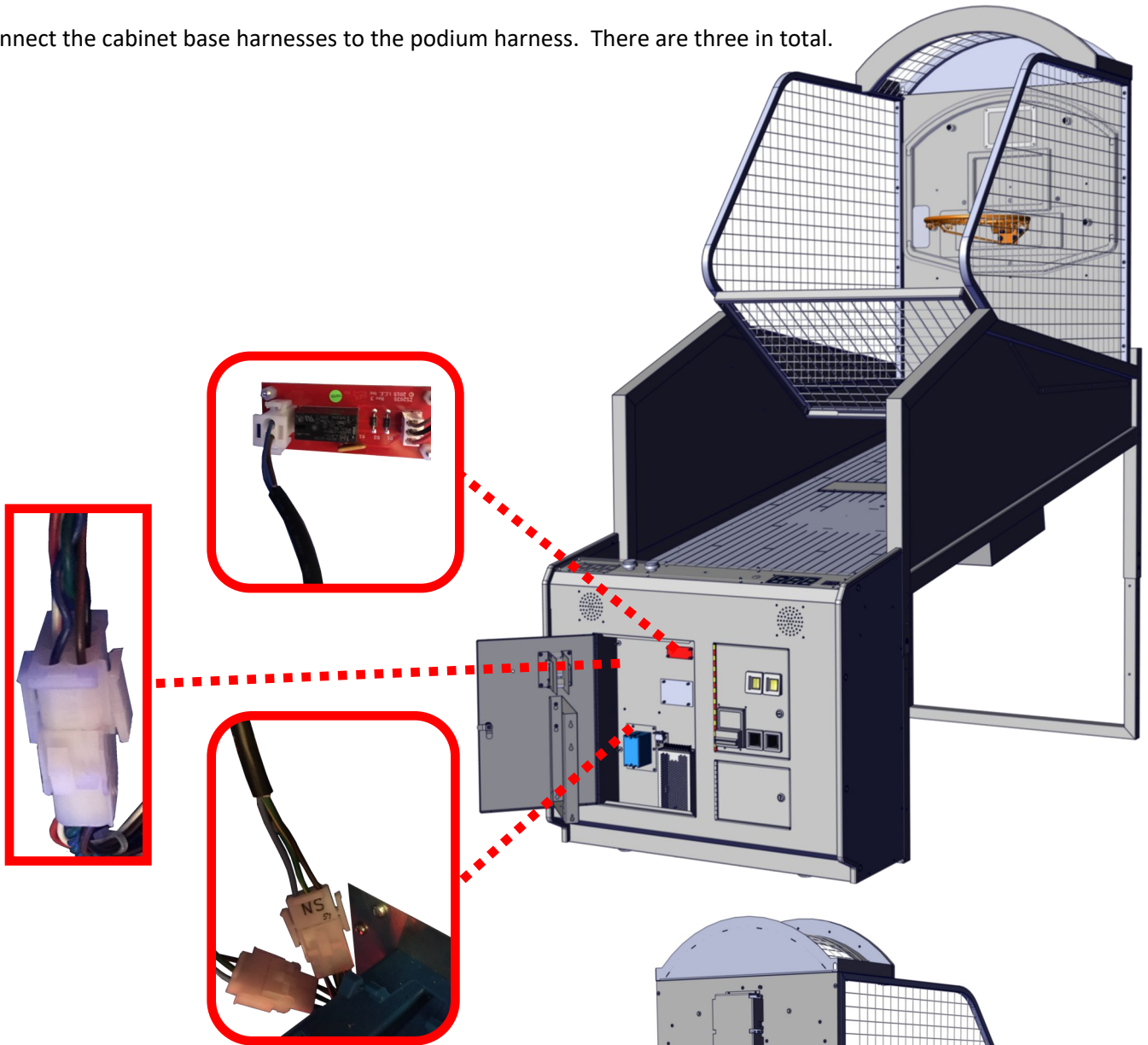

Connect the AC power cord behind the podium. Toggle the AC power button to the "I" position.

The game will power on, run a quick power on test, and go into attract mode. Your game is now fully assembled.



Installing the Lower Skirt: (Optional)

Step 1:

Slide a panel from the back as shown below.

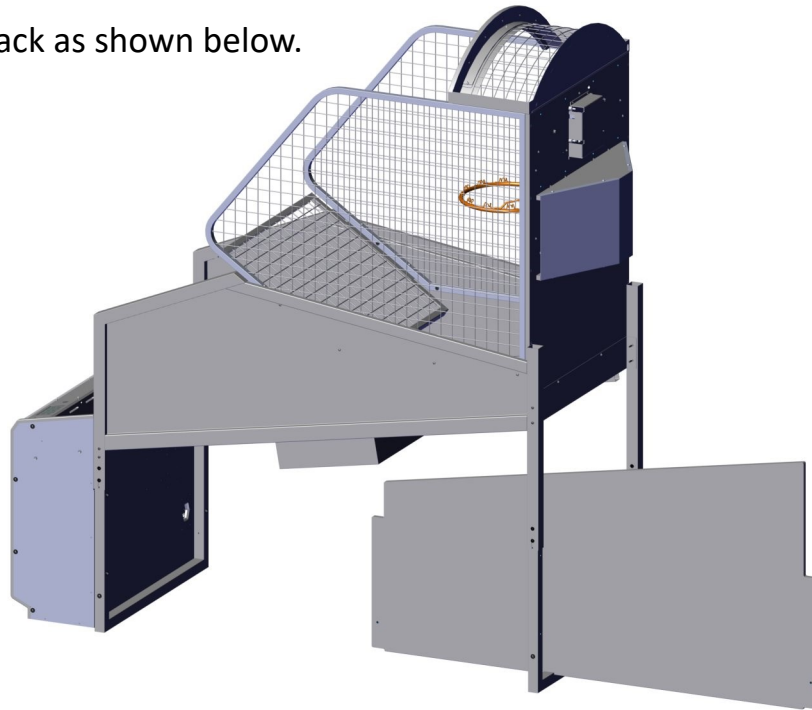

Step 2:

Mount the board using one PC60636 and one AA6212 washer at the bottom front and back.

Repeat for the other side.

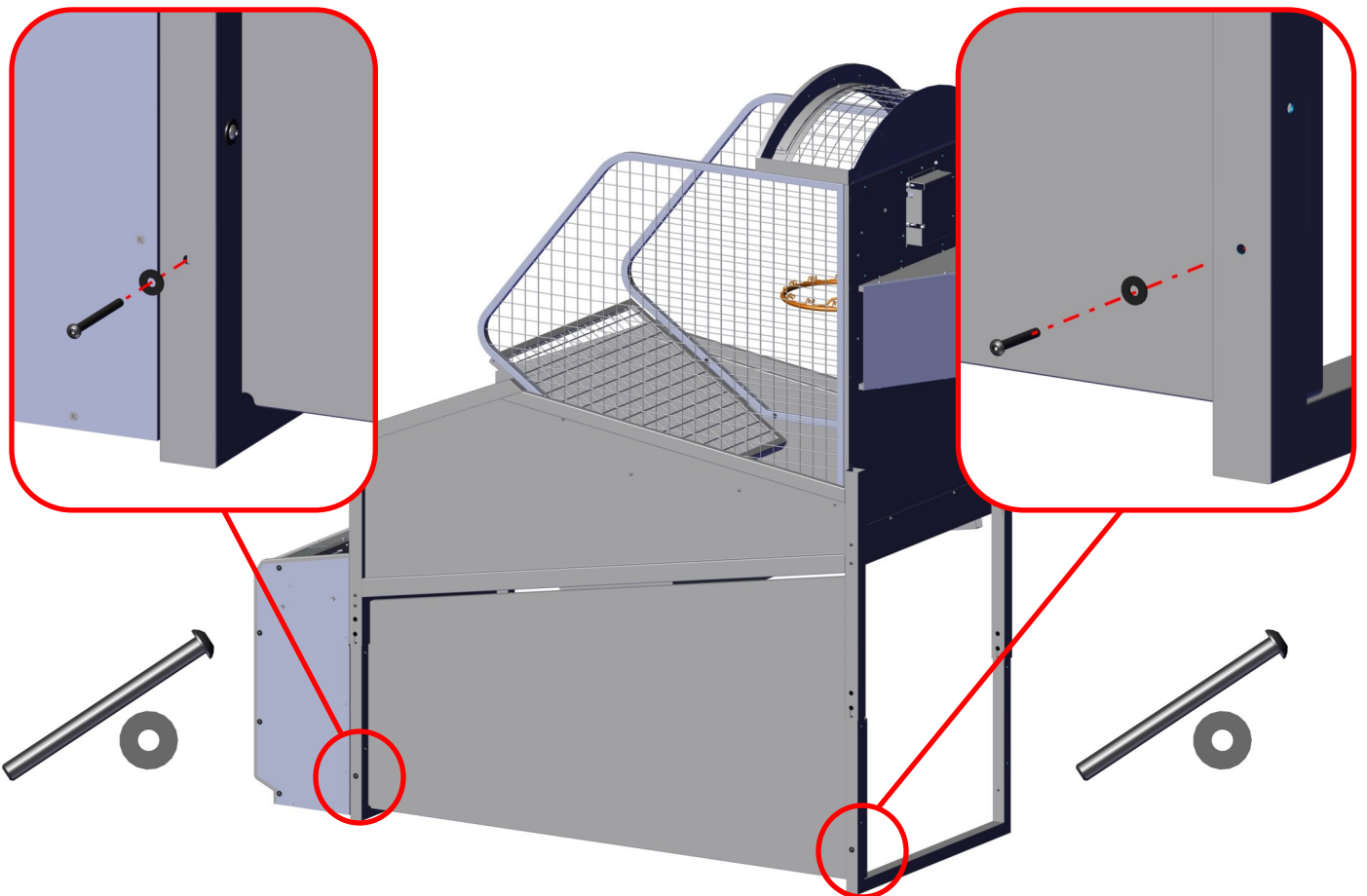

LINKING

To link two or more games together, connect one end of a RJ45 linking cable to the “OUT” (J5) jack of the first cabinet. Then connect the other end into the next game at “IN” (J4). Continue to connect cabinets this way until you get to the last cabinet. This cabinet you would connect a cable from the “out” (J5) to the “TERM” (J9) connector of the last cabinet.

No software options need to be changed in order to enable linking!

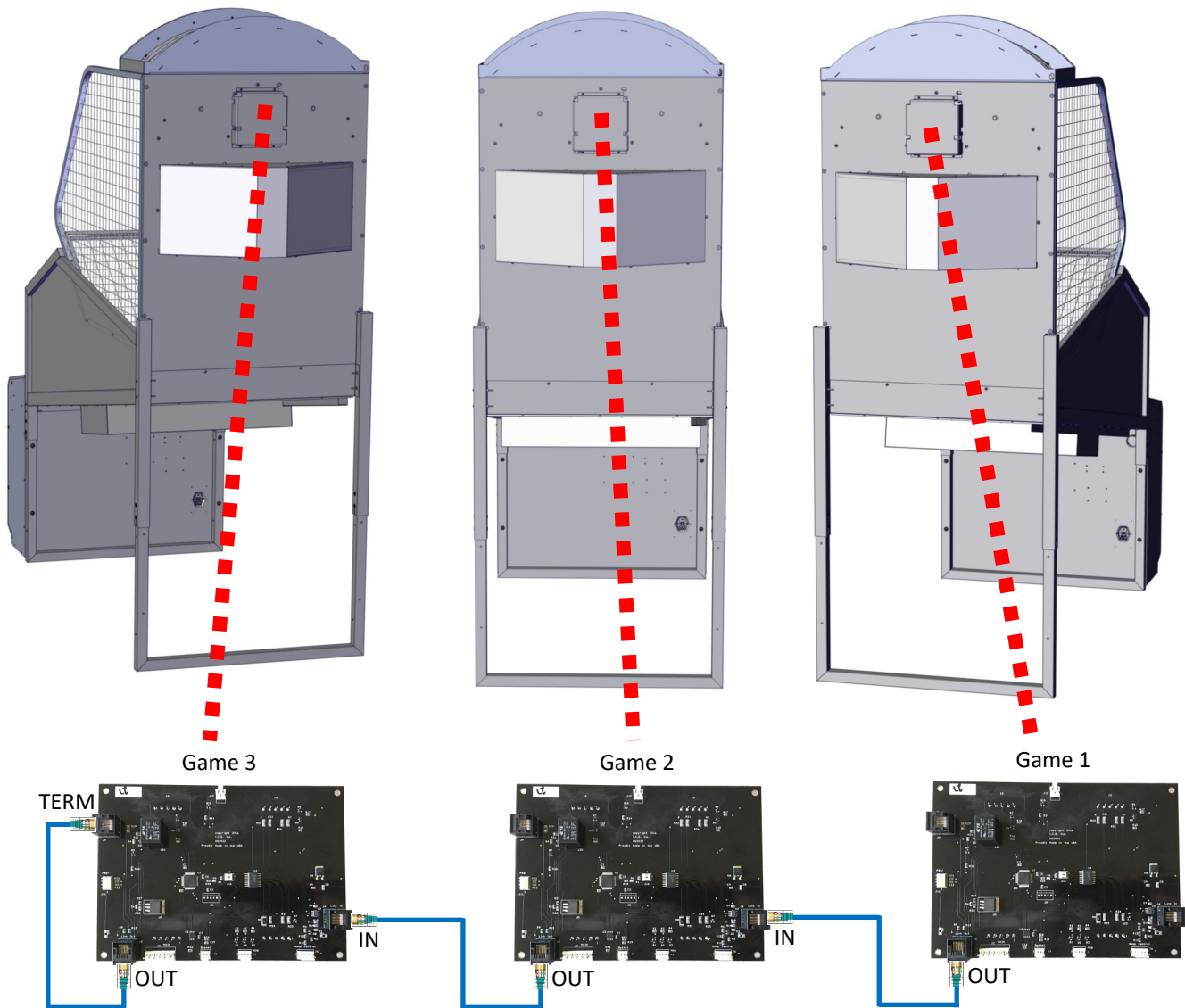

When power is applied, the game will display its version number on the back board, then pause, show it's assigned ID, then go into attract mode. If the game shows dashes instead of a assigned ID number, there was failed communication between the games. Double check connections go in to out and term is installed in last game.



NEVER MOVE GAMES WITH LINK CORD ATTACHED!

Mega Marquee Two Game Install

To install a Mega Marquee onto two games attach one NS1031 support bracket to the left game with two AA6094 hex bolts, two AA6212 washers, and two NS3004 spacers.

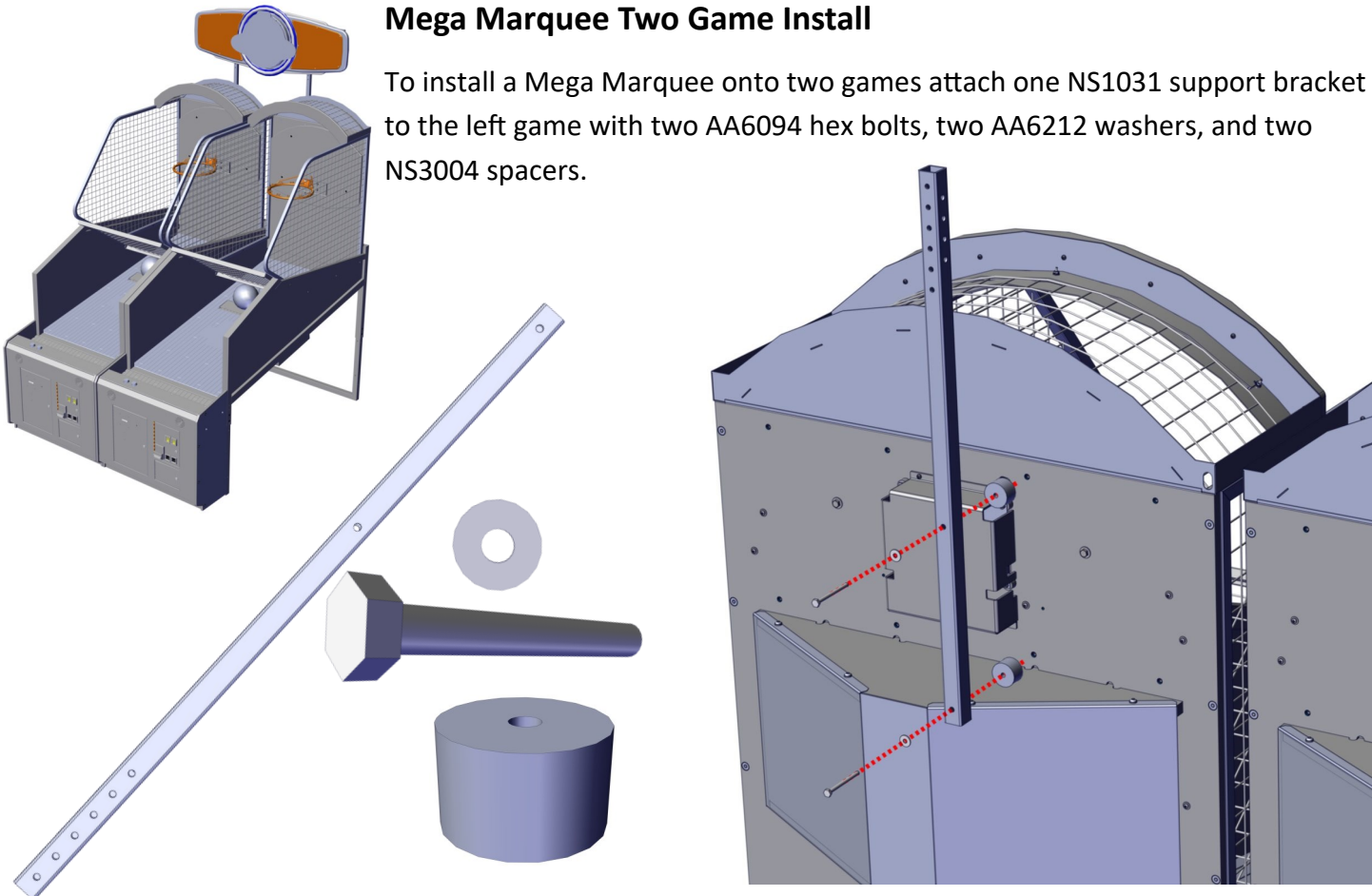

Then attach another NS1031 support bracket on the right game with two AA6094 hex bolts, two AA6212 washers, and two NS3004 spacers.

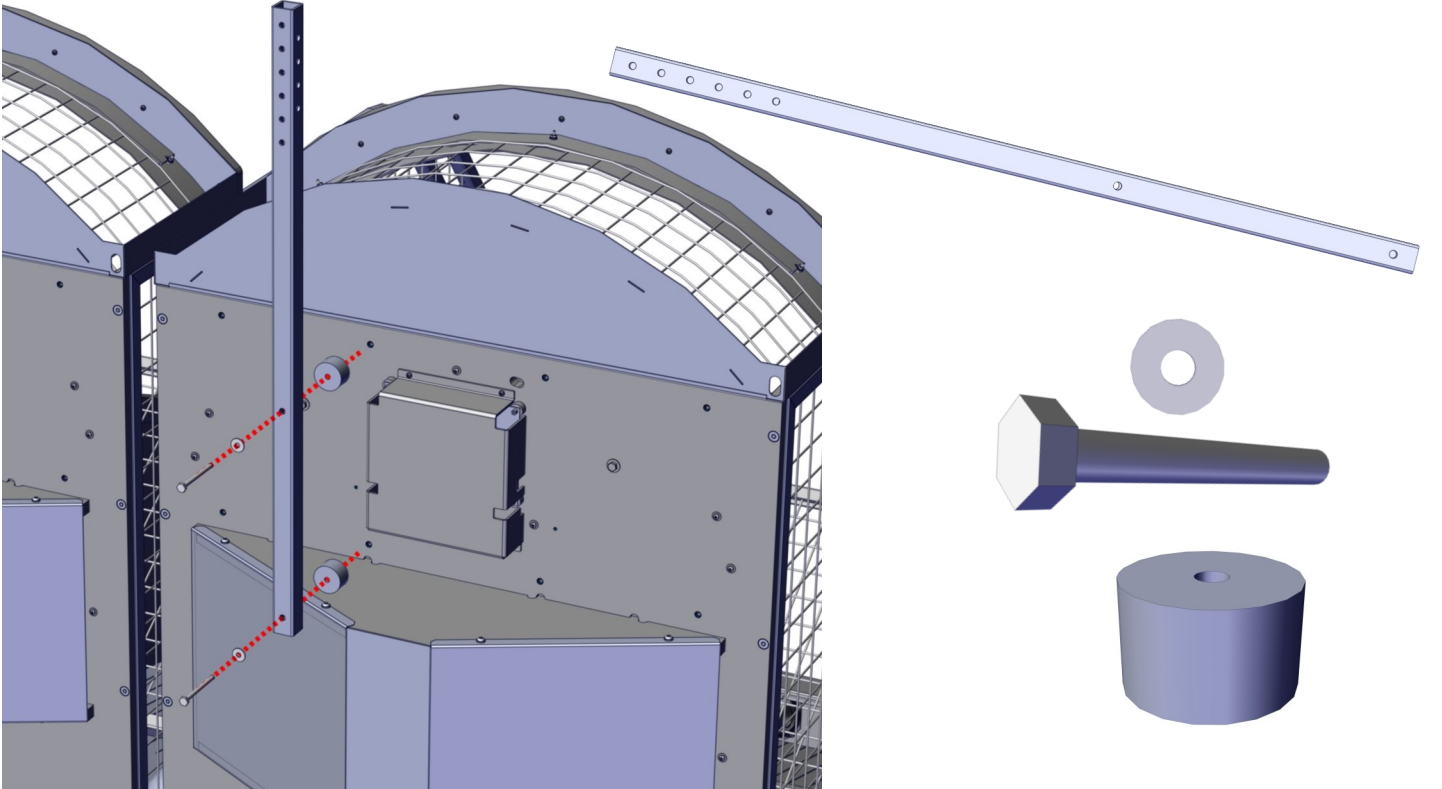

Mega Marquee Three Game Install



To install a Mega Marquee onto three games attach one NS1031 support bracket to the center game with two AA6094 hex bolts, two AA6212 washers, and two NS3004 spacers.

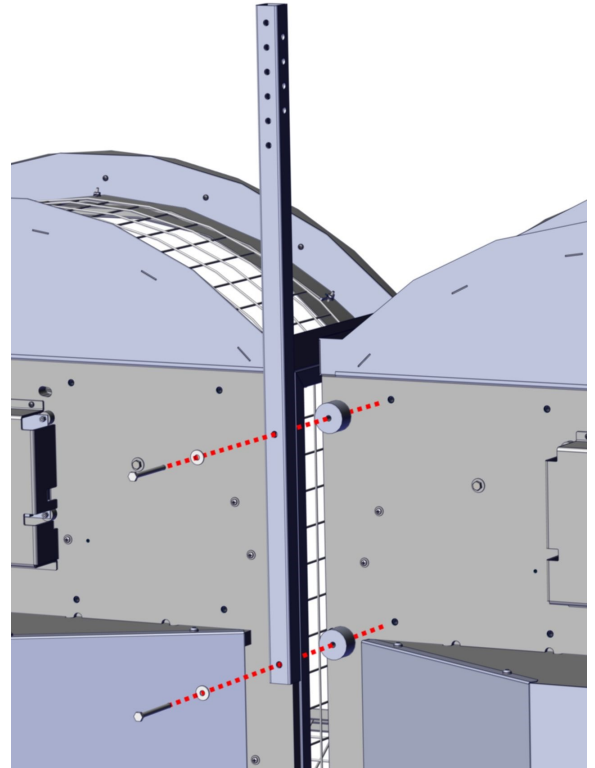
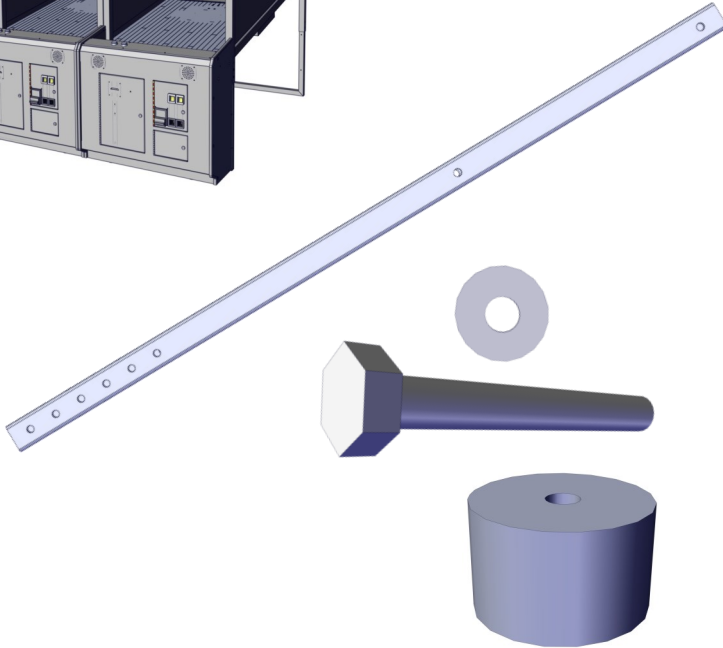

Then attach another NS1031 support bracket on the same game with two AA6094 hex bolts, two AA6212 washers, and two NS3004 spacers.

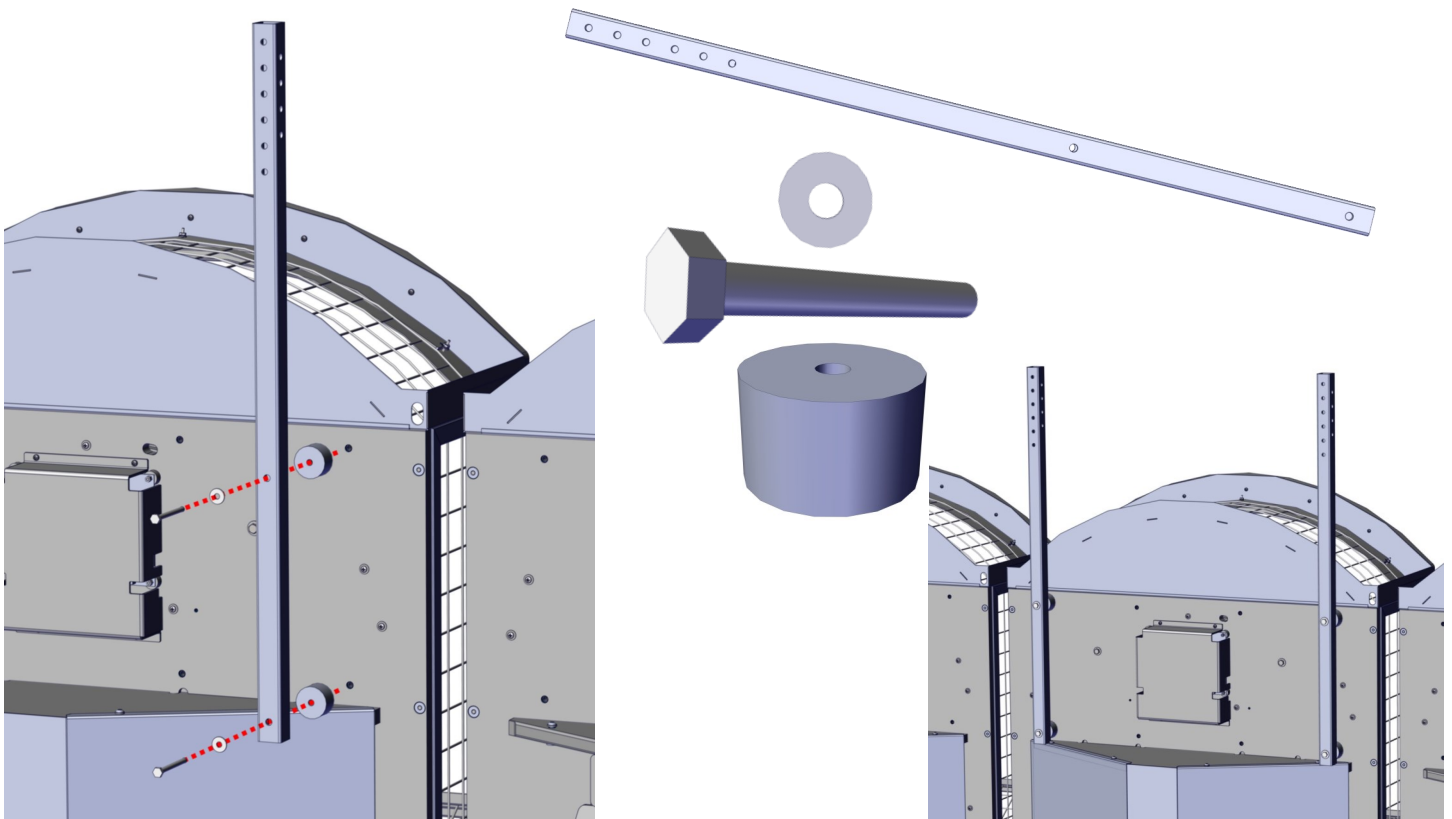

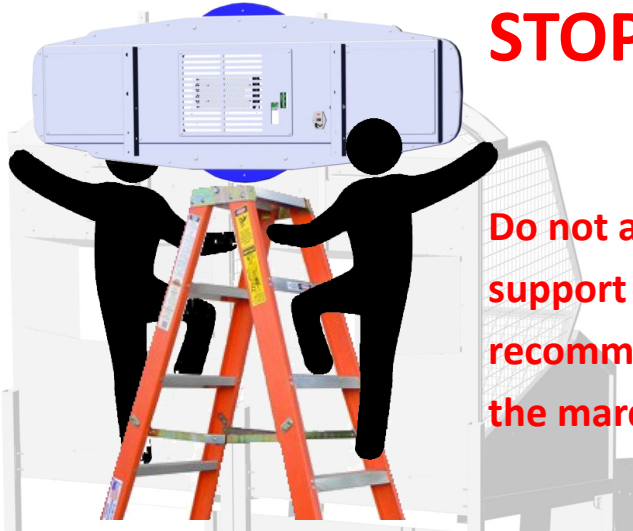

STOP!

Do not attempt to lift the marquee up on the support brackets without sufficient help. We recommend at least one additional person to lift the marquee up onto the support brackets.

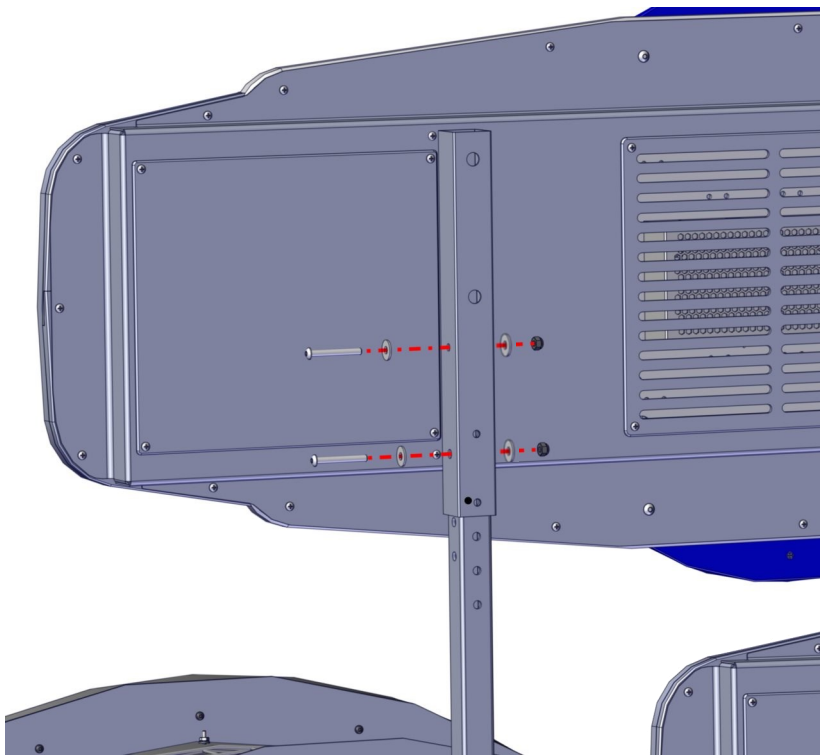

Secure the Mega Marquee with four AA6917 Allen bolts, eight AA6212 washers and four PC60604 nylon nuts.

Diagram shows one side.

Then at the back use one AA6635 hex bolt and AA6212 washer at the top hole. The bottom hole use AA6917 and AA6212.

REPEAT FOR THE OTHER BRACKET.

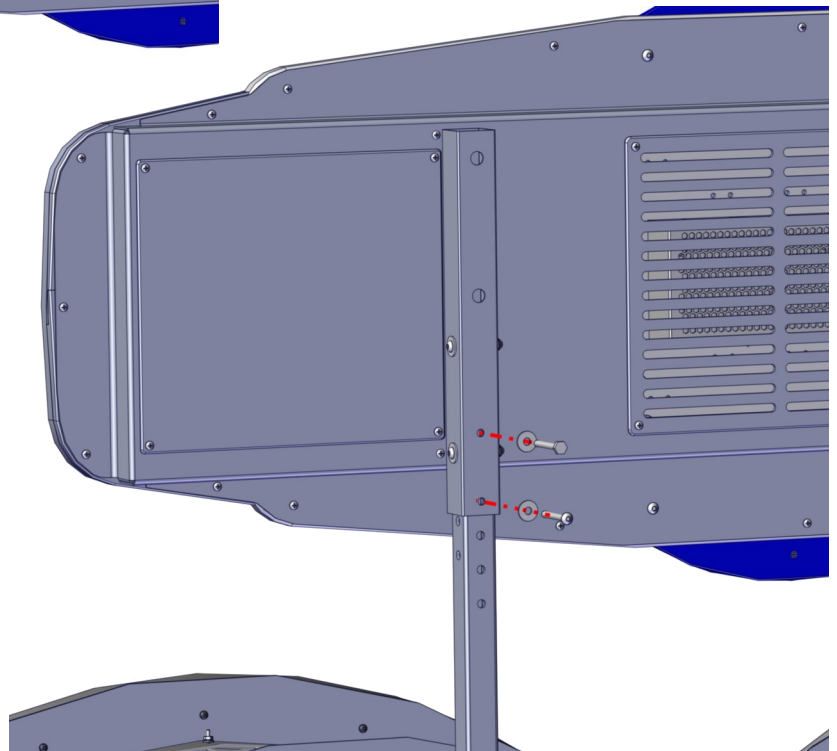

Marquee Linking

To link the marquee to two or more games, connect one end of a RJ45 linking cable to the “IN” (J4) jack of the first cabinet (GAME 1). Then connect the other end into the “IN” of the marquee.

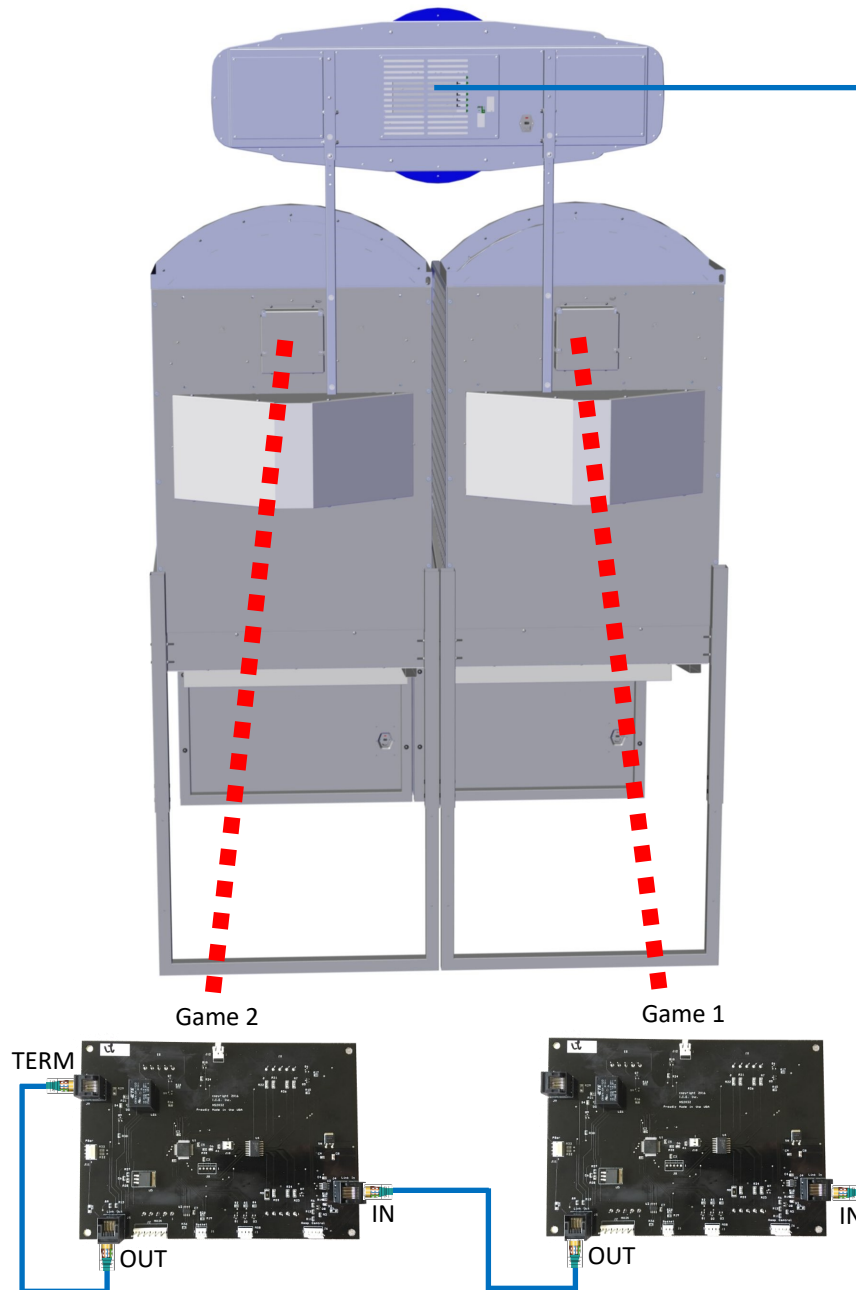

When power is applied, the game will display its version number on the back board, then pause, show it's assigned ID, then go into attract mode. If the game shows dashes instead of a assigned ID number, there was failed communication between the games. Double check connections go in to out and term is installed in last game. The Marquee will display dashes when there is no communication.



NEVER MOVE GAMES WITH LINK CORDS ATTACHED!

Programming Options

Game options can be changed in program mode. The game must be in attract mode (no one playing the game) to enter program mode. Open the coin door to access the program button. Press the program button to enter program mode. The right display (SCORE) shows you option value while the left display (HIGH SCORE) shows you the option number. Pressing the “SELECT” button advances to the next option while pressing “UP” or “DOWN” buttons will change the value for that option.

The next page details the options available and their meanings.

NOTE: THIS IS A ONE PLAYER GAME ONLY.

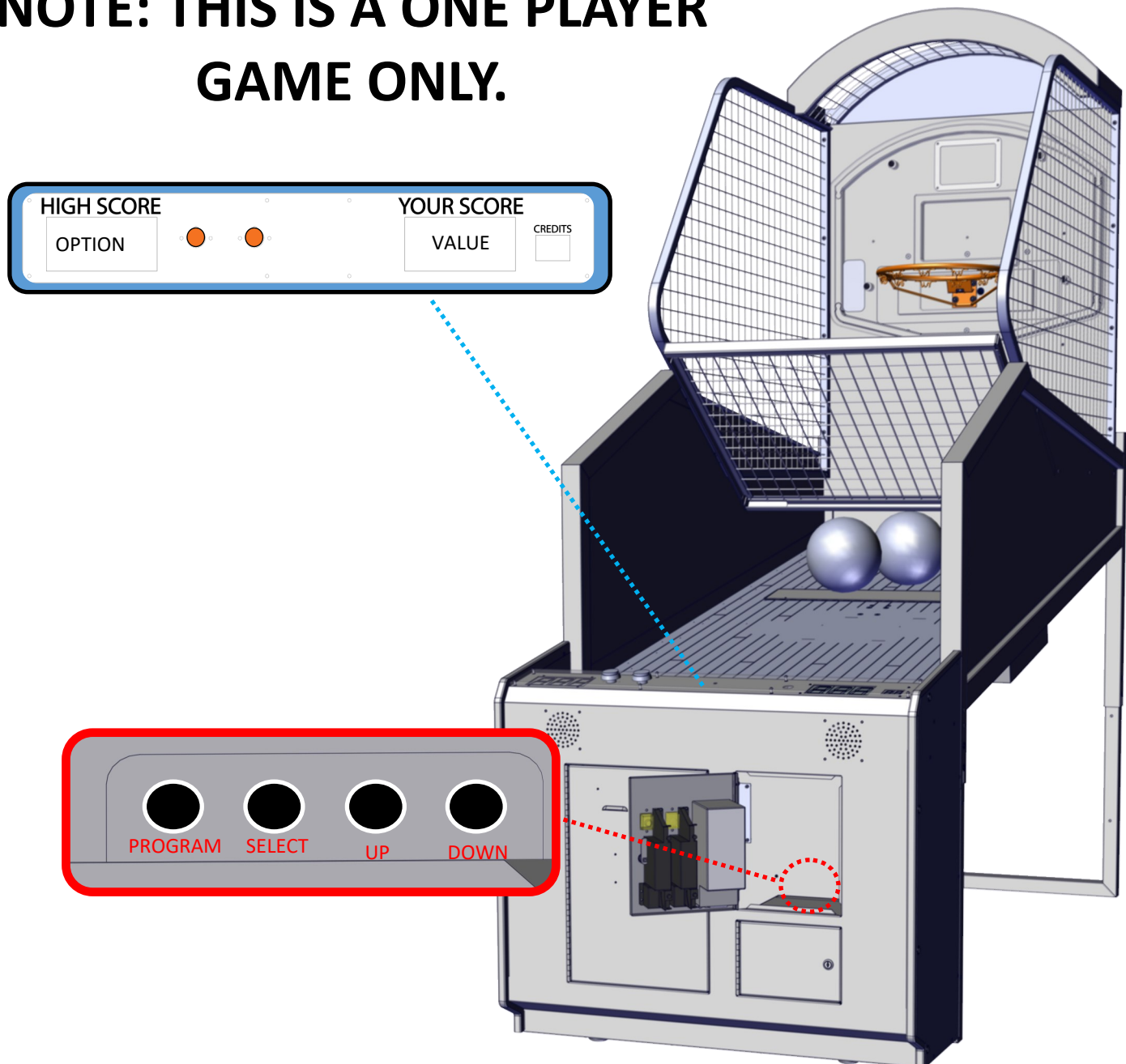

<u>Option</u>		<u>Default</u>	<u>Min</u>	<u>Max</u>	<u>Inc</u>	
0	Game Volume	4	0	4	1	"Game Volume"
	<i>This option adjusts the volume levels for game commentaries and announcements.</i>					
1	Background Volume	4	0	4	1	"Background Volume"
	<i>This option adjusts the volume of ambient noises and music.</i>					
2	Coin 1	1	0	9	1	"Cost of Credit"
	<i>Defines how many pulses are needed to give one credit to start a game. A pulse can come from either the coin switch or dollar bill validator. Setting to 0 puts the game in free play.</i>					
3	Coin 2	1	0	10	1	# of Coin 1's
	<i>Coin line 2 wire is worth X many pulses of coin 1 pulses. For example a dollar coin is worth 4 quarters. If you attached a quarter to coin 1 wire and a dollar mech to coin 2 wire you would set this option to 4 because a dollar is worth four quarters (pulses).</i>					
4	DBV	4	0	10	1	# of Coin 1's
	<i>DBV line is worth X many pulses of coin 1 pulse. Your DBV can be set in two ways. If the DBV is set to 4 then this option is set to 1. If your DBV is set to 1 then this option is set to 4.</i>					
5	Discount	0	0	9	1	"# of Games til Disc"
	<i>When a value is other than 0 that many games purchased in a row (before starting a game) will result in one free game.</i>					
6	Games Per Credit	1	1	9	1	"# of Games Added per Credit"
	<i>This option allows you to give more than one game per credit. For examples if this option is set to 2 and a player has purchased one credited, the game will give the player two games for that one credit.</i>					
7	Game Time	45	30	60	1	"Game in Seconds"
	<i>The value of this option determines the total game time.</i>					
8	Attract Time	2	0	30	1	"Attract time"
	<i>How many minutes should the attract mode should run. The type is set in option 7.</i>					
9	Attract Type	3	0	3	1	Hoop Move 0/2, Audio 0/1
	<i>A value of 0 = no attract mode, 1 = audio only, 2 = backboard movement only, and 3 means both audio and backboard movement.</i>					
10	Points per ticket	5	1	50	1	Points per tickets
	<i>This value is divided into the total amount of points earned to determine the amount of tickets to be paid. For example a value of 5 and the play scored 100 points at the end of the game, the game would pay 20 tickets out.</i>					

11 JFP 0 0 20 1 Just for Playing Tickets

A value set here will pay this amount of tickets no matter how many points scored.

12 Hoop Motion Game 1 0 1 1 Hoop Motion On = 1 Off = 0

This option will disable the back board from moving.

13 Link Time 0 0 10 5 How long to Wait for Link time

This option allows you to wait for this amount of time for other players to coin in before starting a game. (for linked games only).

14 High Score Ticket Bonus 100 0 2500 10 Bonus Tickets

This option sets how many tickets will be paid out if the high score is achieved.

15 Default High Score 101 50 250 5 Default High Score/ Not saved

This option sets the high score on power up.

16 Save High Score 0 0 1 1 1 = Save, 0 = No Save

This option tells the game to remember the high score or not.

17 Ticket Cap 0 0 50 1 Max Tickets Given per game, 0 = off

This option will limit the total amount of tickets that can be paid.

18 Ticket Multiplier 1 0 2 1 0-JFF/Free, 1-Normal, 2-1/2 physical

This option allows you to turn off tickets or divide the amount of tickets owned in half. Leaving the value on 1 will pay out 1 ticket owed = 1 ticket paid. When set to 1 or 2 options 11 and 17 are used. When both 18 and 11 are 0 and 17 is 1 the game will give a free game instead of tickets. If 18 and 17 are 0 but 11 has a value, those tickets will be paid no matter what the player scores. If 18,11, and 17 are 0 then the game is in just for fun mode and no tickets will be paid.

19 3 Point Time 10 0 30 1 3 Point time left start time

This option sets the length of time the game will award 3 points instead of 2 at the end of the game. It will not add additional time to the game play.

20 Bonus Round Time 15 10 60 1 Bonus Round Length

This value sets the length of time for the bonus round. This is in addition to the game time. The player must score at least the value stored in option 19 to be able to play the bonus round.

21 Bonus Round Target 50 0 200 2 Target Score for Bonus Round

This is the amount of points needed to play the bonus round at the end of the game. Note, if games are linked, each player will be allowed to play the bonus round regardless of points won if one player achieves the score.

22 Bonus Round Points 1 1 3 1 Points per Basket Bonus Round

This option allows you to set the amount of points for each basket during the bonus round.

23 Hoop Motion Bonus 1 0 1 1 Hoop Motion On = 1 Off = 0

You can enable or disable the backboard from moving during the bonus round. This will not change the settings for game play or attract motion.

24 Color 1 0 1 6 1 Attract Color 1

This option is for color 1 of the attract colors the game will cycle through during attract mode.

25 Color 2 2 1 6 1 Attract Color 2

This option is for color 2 of the attract colors the game will cycle through during attract mode.

26 Color 3 4 1 6 1 Attract Color 3

This option is for color 3 of the attract colors the game will cycle through during attract mode.

27 Factory Reset 0 0 1 1 Factory Reset

A setting of 1 will reset and load all default values to the game.

28 Reset credits/tickets 0 0 1 1 Clear tickets owed or credits in.

29 REV 200 N/A N/A N/A Rev of software installed

Ticket out options:

Normal Tickets

½ Tickets

Just For Fun

Set Tickets

Free Game on High Score

Options that need to be set:

18 = 1, 11 and 17 used

18 = 2, 11 and 17 used

18 = 0, 11 = 0, 17 = 0

18 = 0, 11 = Tickets, 17 = 0

18 = 0, 11 = 0, 17 = 1

Color codes

Color 0 Red

Color 1 White

Color 2 Blue

Color 3 Orange

Color 4 Green

Color 5 Yellow

Color 6 Pink

Color 7 Purple

**Keeping the game balls slightly soft,
will ensure more control,
and better gameplay!**

Programming Options for Mega Marquee 1.01

<u>Option</u>		<u>Default</u>	<u>Min</u>	<u>Max</u>	<u>Inc</u>	
0	Score Base	75	25	250	1	Lowest Score
1	Ticket Base	100	0	9975	25	Tickets for High Score
2	Games To Dec	5	0	100	1	How many Lost games to Dec Score
3	Dec Amount	5	1	20	1	When Dec change by this amount
4	Games to Inc Tickets	1	0	100	1	Game losses to Inc Tickets
5	Inc Amount	1	1	20	1	How many Tickets when Inc'd
6	Save High Score	0	0	1	1	High Score remains for power cycle
7	Color 1	0	0	7	1	Color 1
8	Color 2	4	0	7	1	Color 2
9	Color 3	2	1	7	1	Color 3
10	Color Speed	5	0	20	1	Speed of Color Cycle

Selected Color Numbers

Color 0 Red

Color 1 White

Color 2 Blue

Color 3 Orange

Color 4 Green

Color 5 Yellow

Color 6 Pink

Color 7 Purple

Note:

To enter programming mode you must be on linked game #1. Press the "Down" button to enter programming mode. You cannot be in game programming mode to do this. After that the Marquee will show a PO and a value. That is option #0. Pressing the select button will cycle thru the modes. Pressing the up button will increment the option wrapping if you go to far. Pressing the "down" button will decrement the option, again wrapping if you go to low.

To exit Marquee programming press the "prog" button. Doing this once will exit programming of the marquee and pressing it again will enter programming for the game.

Maintenance

Back Board Maintenance - Game Time / Hoop FX

The hoop assembly moves left and right by two Delrin blocks that ride on a HPDE channel. After a period of time it might become necessary to lubricate these parts to allow smooth operation. We suggest spraying WD-40 into the grooves and on the Delrin blocks where it contact the HPDE channel.

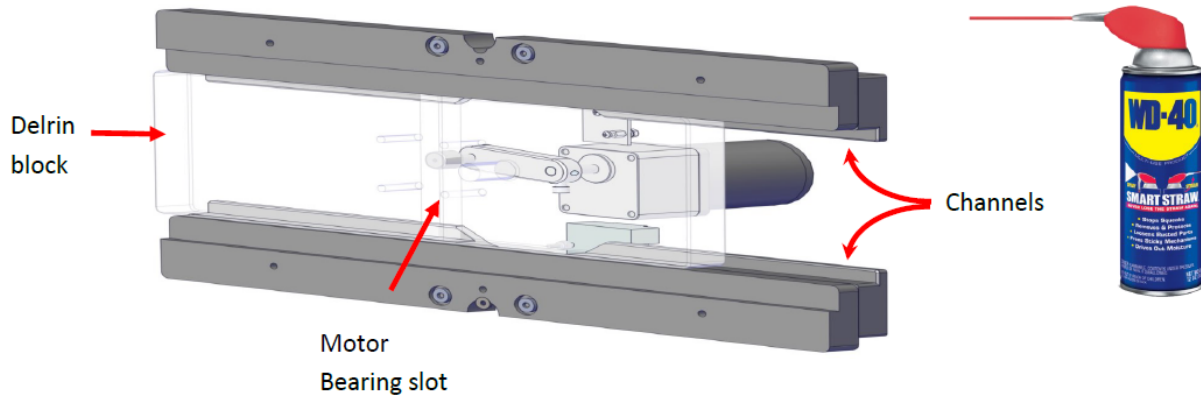

Ball Inflation

We suggest that all of our basket ball games have five basket balls loaded into them for the best play experience. Each ball should be inflated so that when you push down with your two thumbs, the ball should depress about $\frac{1}{2}$ " to $\frac{3}{4}$ ". If you bounced the ball, it should only bounce one full time. Too much pressure will cause the balls to bounce out of the machine while too little will give the player a poor experience.

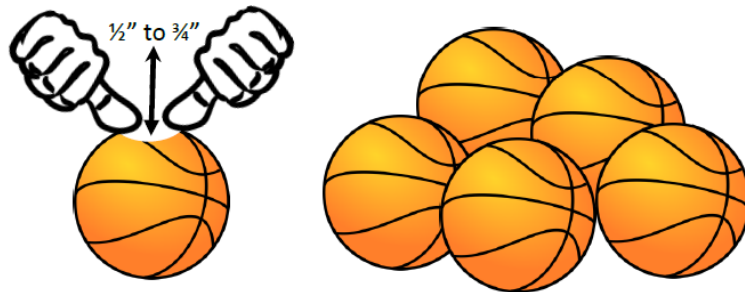

Trouble Shooting : Linking Your Games

It is important to set each game option the same between games. Setting games to different settings would confuse the players when they are competing head to head. Players would win different amounts of tickets at different scores or be charged differently to play games.

When a marquee is used, the marquee will show the points needed to score and the amount of bonus tickets that can be win. If all games are set differently, the marquee will use the highest settings for those two options out of all the linked games.

When the games are powered on they will first display the version number of the software installed and preform a self check. Then they will determine what station ID they are. This is displayed then as "ID" and then a number. The game will continue to show dashes until it has determined what station ID it is. A setting in the software will determine how long to wait before going into game mode. This occurs if no communication is found. This setting can be increased if more games are linked together requiring more time for them to communicate.

**NOTE: THIS IS A ONE PLAYER
GAME ONLY.**

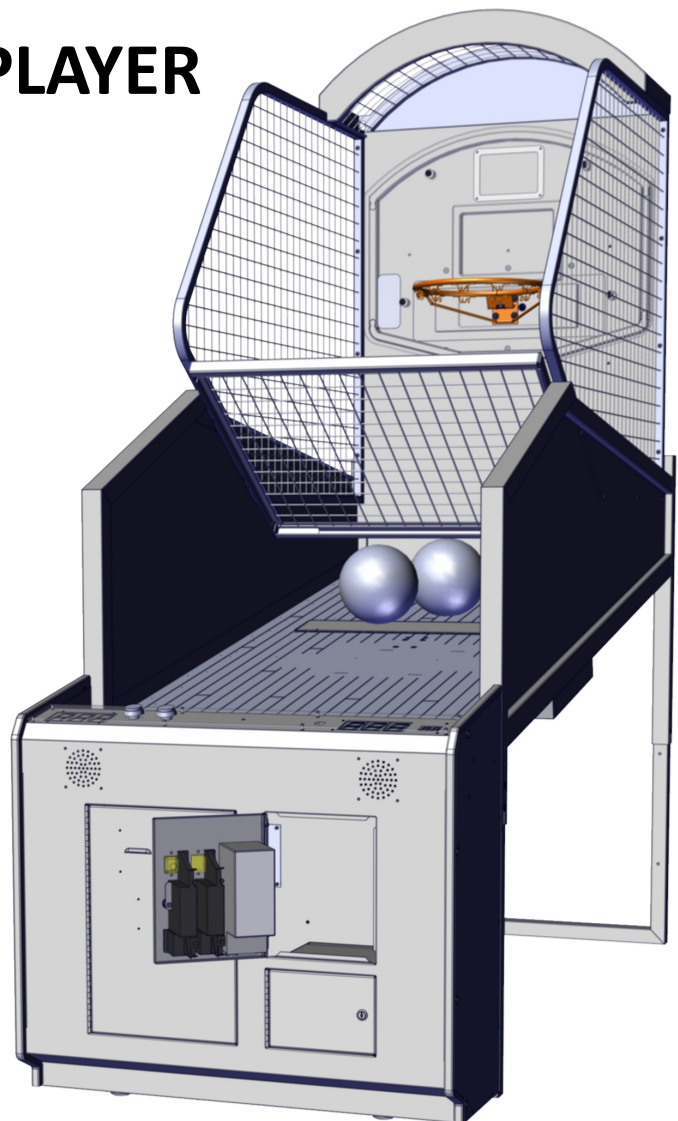

LINKING

If the games do not ID themselves at startup you will need to isolate the problem to either one of the display boards or one of the cables. It is recommended to isolate the games to pairs when working with three or more games. In this example below, it is recommended to unplug the connector going “in” to game 3 and move it to “TERM” of game 2. Reboot the game.

If it correctly configures the ID then move the back board display of game 3 to game 2 to retest. At this point if the game no longer will correctly configure, replace the back board display.

If it never configured correctly replace the cable from game 1 “out” to game 2 “in” with another cable. Although the cables are standard and can be tested with a cable tester the connection between games are not standard and contain harmful voltages. They are designed only for use with ICE products. Once you have two games linked and working, test the remaining cables between the “out” of game 1 and the “in” of game 2.

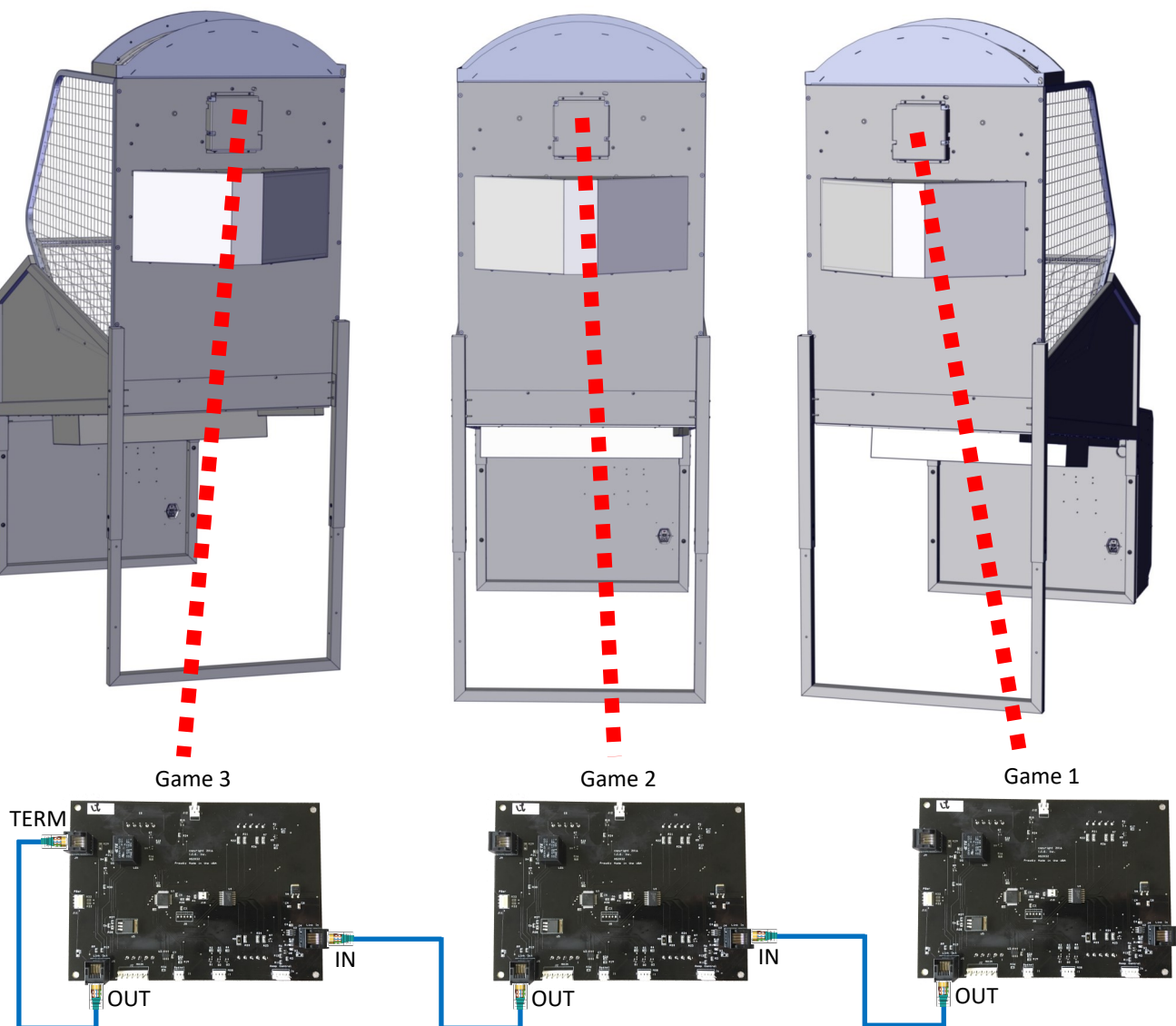

Marquee Linking

When the marquee is powered on it will display dashes until the it can communicate with other linked games. At anytime the communication is lost the display will show dashes. If the marquee power is applied after the games are powered on, the marquee will not establish communication with other games. Always power the marquee on first or at least at the same time with the games. Powering games on first will result in the marquee not linking.

The marquee can only be plugged in before Station ID 1 game or the game that has no input from another game plugged in. The marquee is always the first game in the chain.

If the marquee cannot establish any communication with other games start by replacing the link cable. Then check to see if the last game has the "OUT" connected to "TERM" of the same game.

Unplug the marquee and power on games. Do the games assign themselves station ID's?

If yes and you have replaced the cable then replace the marquee board.

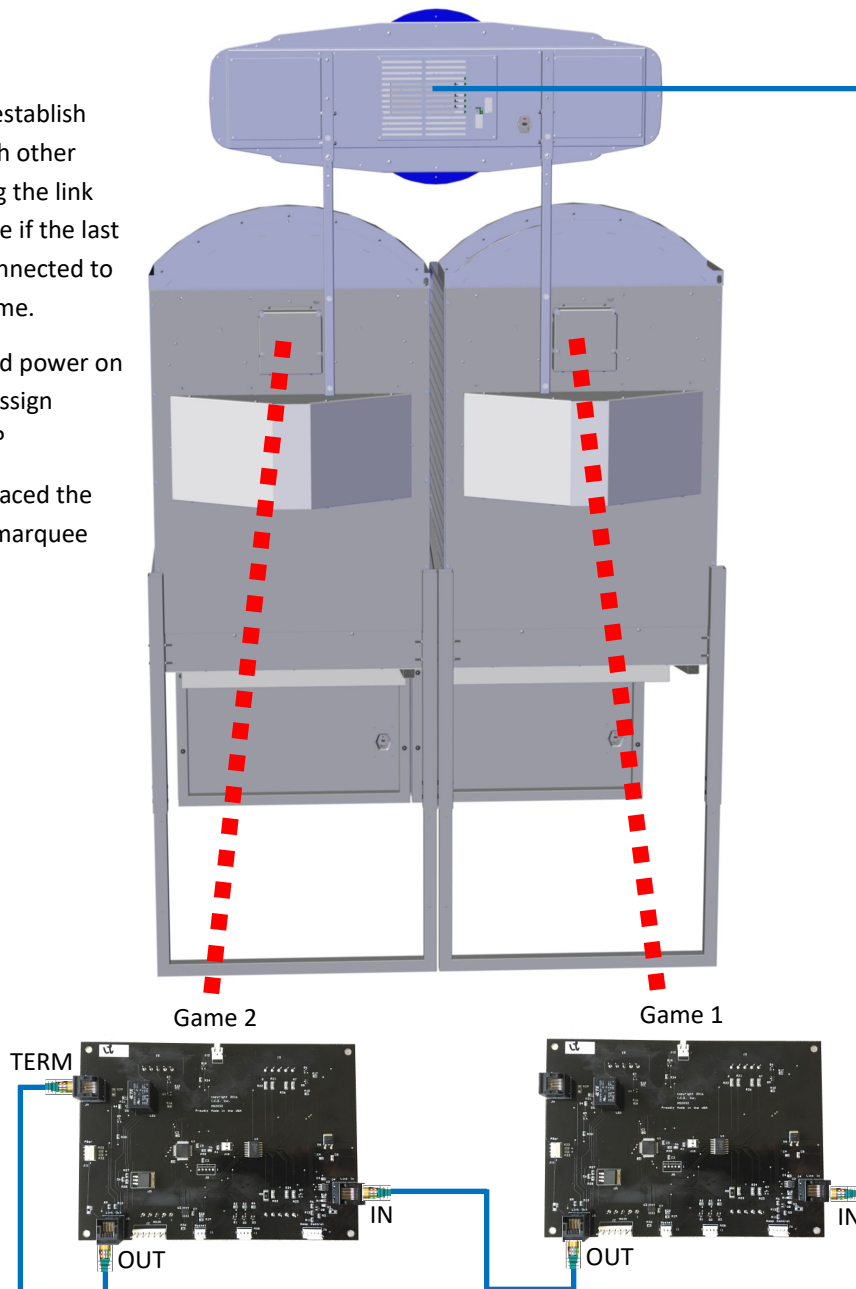

Score sensor theory of operation

The game uses an intelligent reflective sensor to register a score during the game. The sensor operates by transmitting a beam of light from the transmitter LED and then looks for the beam to be bounced back at the receiving LED. Both of these LEDs are intergraded into a single sensor assembly. The light that is transmitted from the sensor is red and it can be seen with the naked eye when a white piece of paper is held in front of the sensor assembly.

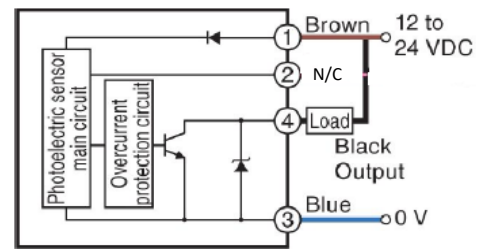

Net sensor troubleshooting

If shots do not register

Check for +12 VDC power to the net sensor, this can be done visually or with a voltage meter. A red LED facing the customer and a green LED on the lower left side are visual indicators the sensor has power. To use a voltage meter, at the back of the sensor attach the red probe on the Brown wire (12 VDC) and the black probe to light blue/blue wire (ground). The meter should read 12 VDC or within 10 percent of that.

- - If no voltage is present then move the red probe to pin 1 and the black probe to pin 3 at connector J 1 of the score display board.
- - If there still is no voltage and the display is lit then replace the display board.
- - If there is power present at J1 connector then check / repair the harness

Check the signal line of the net sensor. There is a LED visual indicator on the left side of the net sensor that will light orange when the sensor is blocked. You can measure the signal line output to the score display by touching the red probe on the black wire (signal) and the black probe on the light blue/blue wire (ground) at the sensor. The meter should read voltage at 3.3VDC and when blocked, 0 VDC.

- - if the voltage does not change, with the probes previously attached, adjust the sensitivity of the net sensor.
If adjusting the sensitivity still doesn't show voltage, replace the sensor.
- - if the voltage is changing and the score display is on, check and repair the harnessing from the sensor to J1 at the back board.
- - If no problems are found with the wiring then replace the display board.

Net sensor adjustment

The net sensor has a sensitivity adjustment located on the side, below the visual indicator LEDs, to adjust for environmental conditions in your location. Turning the screw clockwise will increase the sensitivity and turning it counter clockwise will decrease the sensitivity.



Back board motor theory of operation

The game uses a motor to move the hoop assembly left and right. A motor arm connects to the motor and rests between two DELRIN blocks that ride on a HPDE channel. The motor will always attempt to keep itself centered. This is accomplished by using an optical sensor to read reflective tape at the back of the motor arm. This determines when it is in the center position. If the sensor board does not see the reflection from the tape, it will activate the motor periodically throughout the game. The motor is activated when the display board sends a low voltage signal to a solid state relay. This relay connects to the motor and controls the incoming A.C. voltage to the motor. When the motor drive signal is present at the relay its internal contacts completes the AC circuit to the motor causing the motor to move the hoop assembly.

WARNING—when servicing the backboard assembly keep your fingers clear of the motor arm to avoid injury!

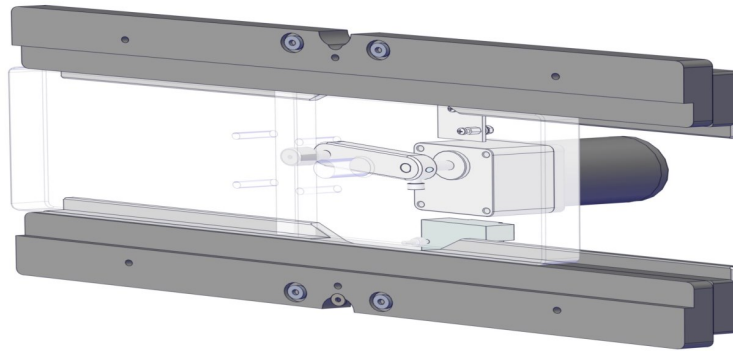

Troubleshooting the back board not moving.

Step 1 - Check option 12 is set to 1. This enables movement.

Step 2 - Check the set screw in the motor arm is tight and engaging the shaft.

Step 3 - Check for incoming AC voltage between tabs 1 and 2 (brown wires) of the solid state relay.

- if there is voltage then proceed to the next step.

- If there is no voltage then inspect the harnessing and all AC inter connections.

Step 4 - check for the signal to turn the relay on. There is an indicator LED on the solid state relay which lights when the signal is present. You can measure this signal using a voltage meter set to DC voltage. Place the red probe on pin 3 (orange/blue trace wire) and the black probe on pin 4 (violet wire). The meter should read 0 VDC when there is no signal. It should change to 12 VDC with a signal present. There will always be a constant 12 VDC on tab 3 of the relay if you use on the back display board at J2, pin 2. If the 12 VDC is not present at this pin, check the voltage at the connector J6, pin 1 on the same board.

- if there is a signal to the relay and the voltage to the motor is present then replace the motor.

- if no signal is present at the relay measure at connector J6 with the red probe on pin 5 and the black probe on pin 1.

- if 12 VDC is present repair the harnessing.

- if there is 0 VDC replace the back display board.

Hoop will not center.

The optical encoder mounted on the rear of the back board assembly reads the reflective tape on the back of the motor arm to determine when the hoop is in the center position. When the hoop is centered it is called the home position of the motor. The back display board will always try to move the hoop to the center position even if the movement is disabled in the software programming.

Step 1 - inspect the optic sensor for signs of physical damage and that the reflective tape on the motor arm is still present and undamaged.

Step 2 - measure the optic board with the red probe on pin 1 (+12vdc , orange wire) and the black probe on pin 3 (ground, black wire). You should measure +12 VDC.

- if you have the correct voltage, proceed to step 3.

- inspect the wiring for damage all the way back to connector J6 on the timer board. If the wiring is good and the display is off, replace the display.

Step 3 - measure at the optic the output (signal) by placing the red probe on pin 2 (signal , white wire) and the black probe on pin 3 (ground , black wire). You should see +5 VDC when the reflector tape is in front of the optic. 0 VDC when it is not.

- If not working in this manner inspect the harnessing and connections to the display board to connector J6. Unplug the connector and measure with the red probe pin 3 and the black probe on pin 4.

- if the voltage is 3.3vdc then replace the sensor.

- if not then replace the display board.

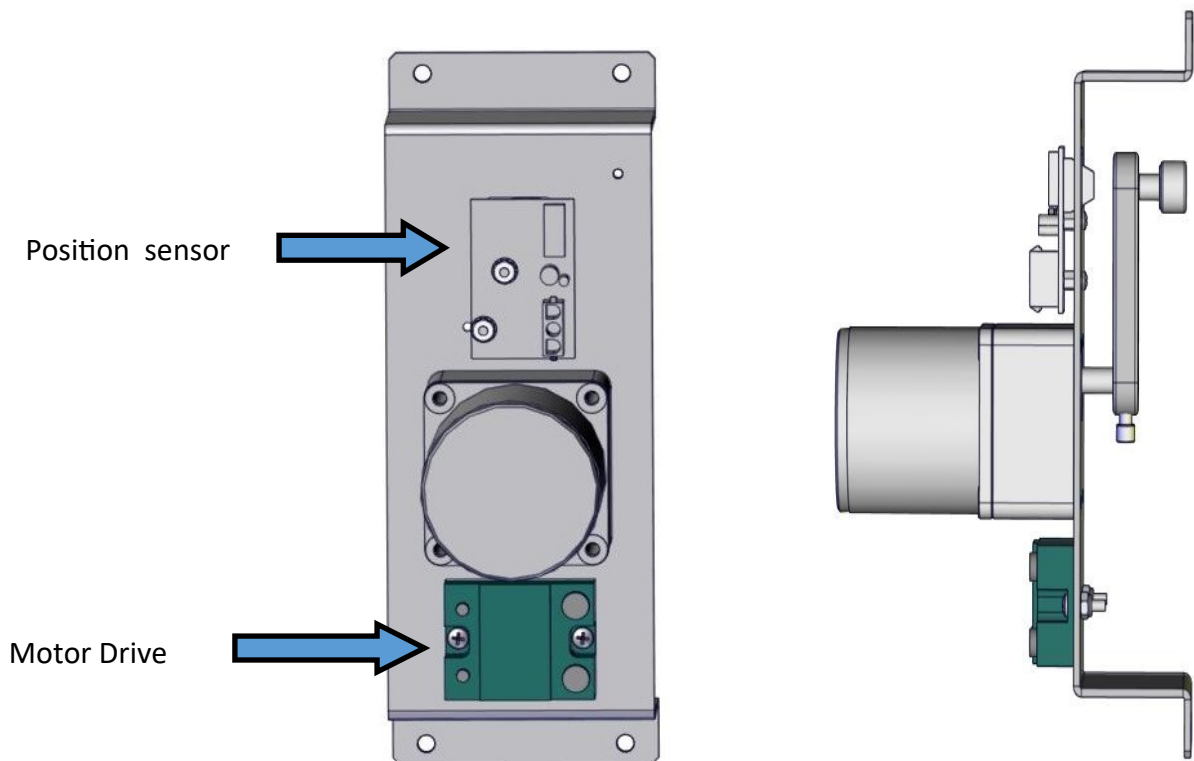

Ball gate theory of operation

The game uses a linear actuator to control the ball gate. The linear actuator has a spring loaded mount that pushes the gate back up if it is pressed down. There are internal limit switches to control the movement of the push rod when it reaches the end of its travel in the actuator. For this reason, there will always be voltage to the actuator. The reason for this is so the gate will remain closed until otherwise told to do so. When the game is started, the main board will send a signal to a relay board located at the front of the cabinet of game. This will reverse the polarity of the voltage to the actuator causing the gate to open.

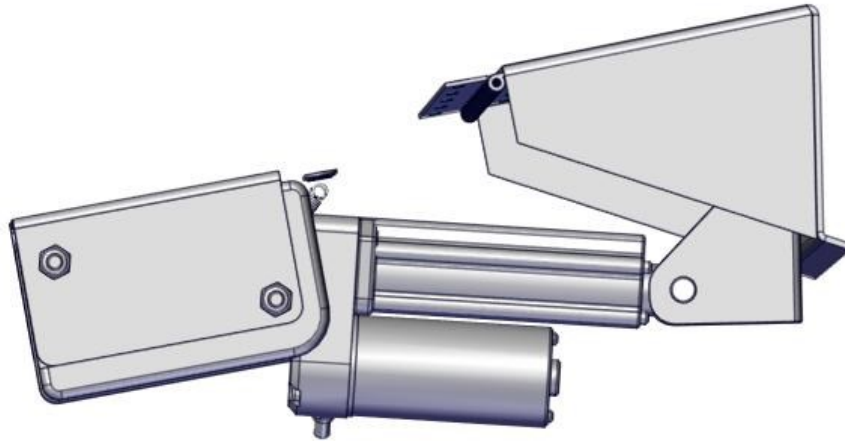

No movement from the ball gate

- Step 1 - inspect the wiring and connections from the actuator to the relay board for signs of damage. This is located inside the front podium.
- Step 2 - check the 12 VDC input voltage to the relay PCB at connector J1 by touching the red probe on pin 1 (orange wire) and the black probe on pin 2 (black wire). You should measure +12 VDC.
 - if no voltage is present check the wires and connections back to J3 connector of the main board.
- Step 3 - Start a game and measure the voltage at J1 again but use pin 3 (brown/yellow wire) for the red probe and pin 2 for the black probe.
 - If no voltage is present and all harnessing and connectors are good, replace the main board if missing.
- Step 3 - check for output voltage on the J2 connector of the relay PCB. In standby mode you will see +12vdc from the black wire (positive, use red probe) to white wire (negative, use black probe). When the game is started the voltage will reverse polarity.
 - if no voltage is present, replace the relay PCB.
 - if voltage is present and the wiring is good to the actuator, then replace the actuator.

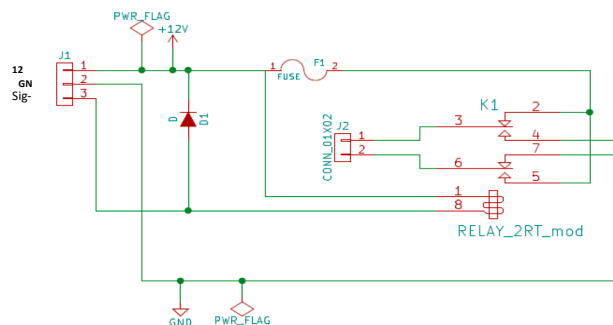

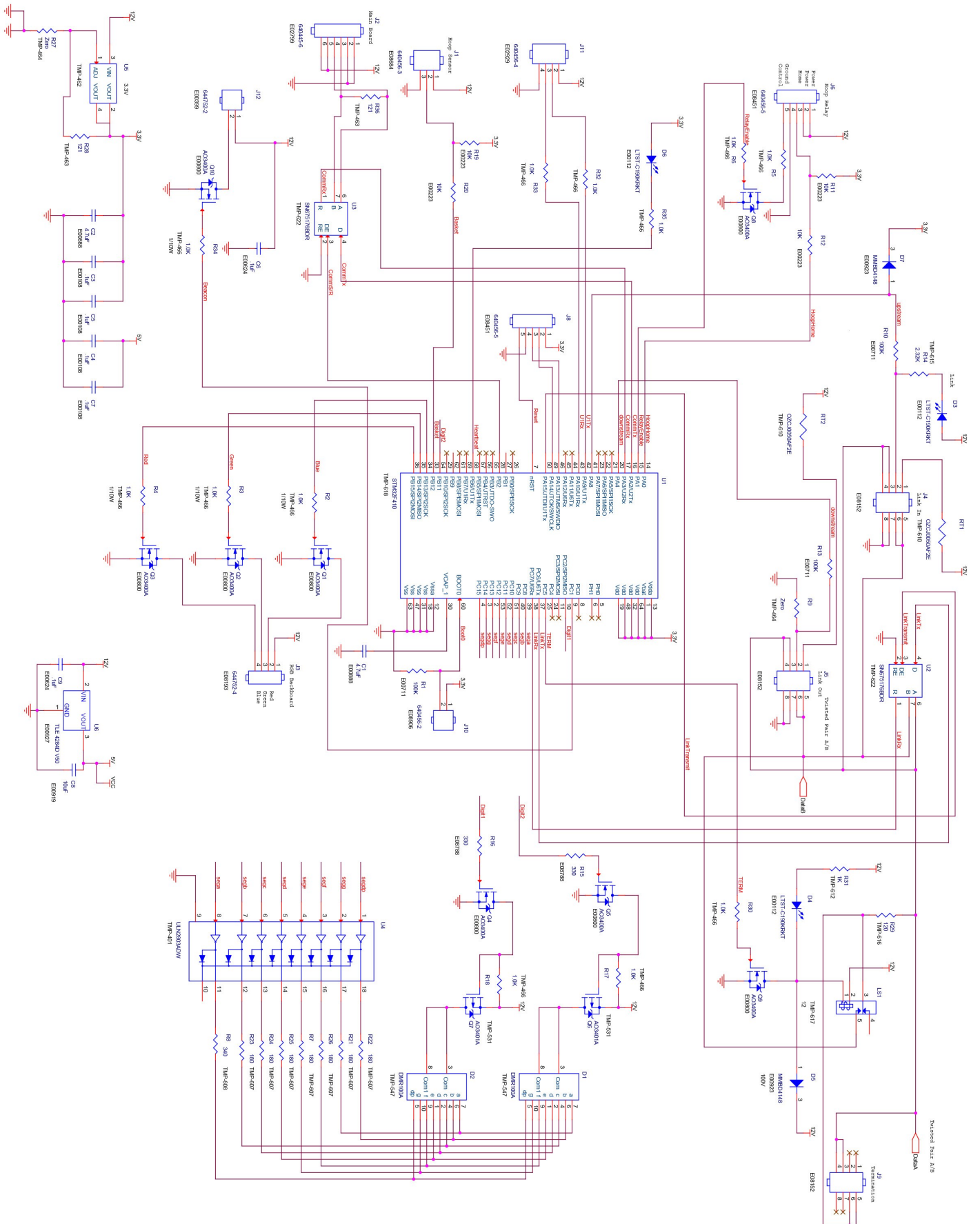

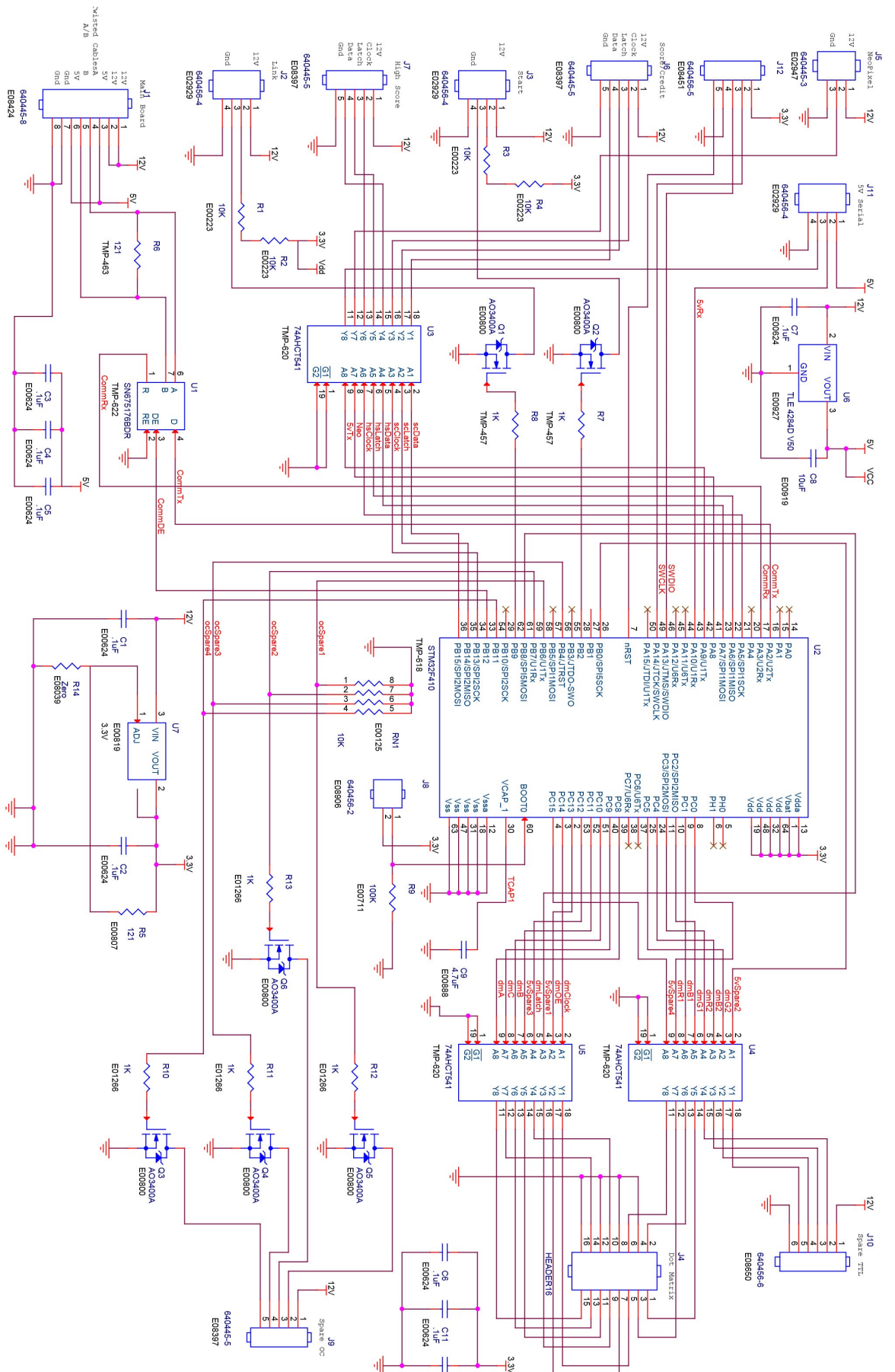

ITEM NO.	PART NUMBER	DESCRIPTION	QTY.
1	NS3070CX	CABINET BACK ASSEMBLY	1
2	MD1239	HOOP ASSEMBLY	1
3	NS1072X	DRIVE ASSEMBLY	1
4	NS3010	RIM MOUNT	1
5	NS3009	RIM GUIDE	1
6	NS3015	SPACER BLOCK	1
7	NS3012	MOTOR SPACER	2
8	NS3011	RIM MOUNT RETAINER	2
9	NS3019	SPACER PLATE	1
10	NS3017	GRIP PLATE (14" x 18")	1
11	4110	1/4-20 RIMM CONNECTOR	4
12	NS3025	BACKGROUND SPACER	4
13	NS3027	BACKGROUND COVER	1
14	NS3034X	BACKGROUND BING ASM	1
15	NS3014	MOTOR SPACER RETAINER	4
16	NS3036X	TARGET BORDER ASM	1
17	AA6062	8-32 X 1-1/4" PRHMS	14
18	AA6031	8 FLAT WASHER	14
19	PC60631	025-20 CABINET INSERT (US0115)	16
20	AA6212	1/4 X 3/4 FLAT WASHER BLACK (USS)	4
21	AA60414	1/4-20 X 3/2" BRCS (BLACK)	16
22	AA60999	1/4-20 X 7/8" BRCS (BLACK) SCREW	4
24	AA6211	1/4-20 X 1-1/4" BRCS (BLACK)	4
25	AA6635	1/4-20 X 2-1/4" HHMB GS W/O	2
26	6075	1/4 X 3/4 FLAT WASHER ZINC (USS)	4
27	3074	O RING - EXPANDED FOR 1/4 BOLT (NB & CB)	4
28	NS3016	DISPLAY COVER	1
29	655	#8 X 3/4 SQ. DRIVE (BLACK)	4
30	AA3053	GROMMET (GRO-7/8-ULL)	1
31	EO0210	HOOP SENSOR	1
32	6567	M3 X 10MM PHMS	2
33	AA8883	10 X 1-1/2 PHMS (BLACK) FORK	2
34	AA6070	1/4-20 X 1-1/2" BRCS (BLACK)	12
35	AA6070	1/4 X 1-1/2 O.D. E-WASHER	8
36	NS3014X	LED FRAME WITH FILTER	1
37	NS2032X	PCBA DISPLAY	1
38	PC60698	8-32 X 1-1/4" PRHMS	4
39	SK624	6-32 KEP NUT	4
40	4002	BUMPER (#2953W) 9540X53	4
41	PC60643	6-32 X 1/4" HH SPACER	4

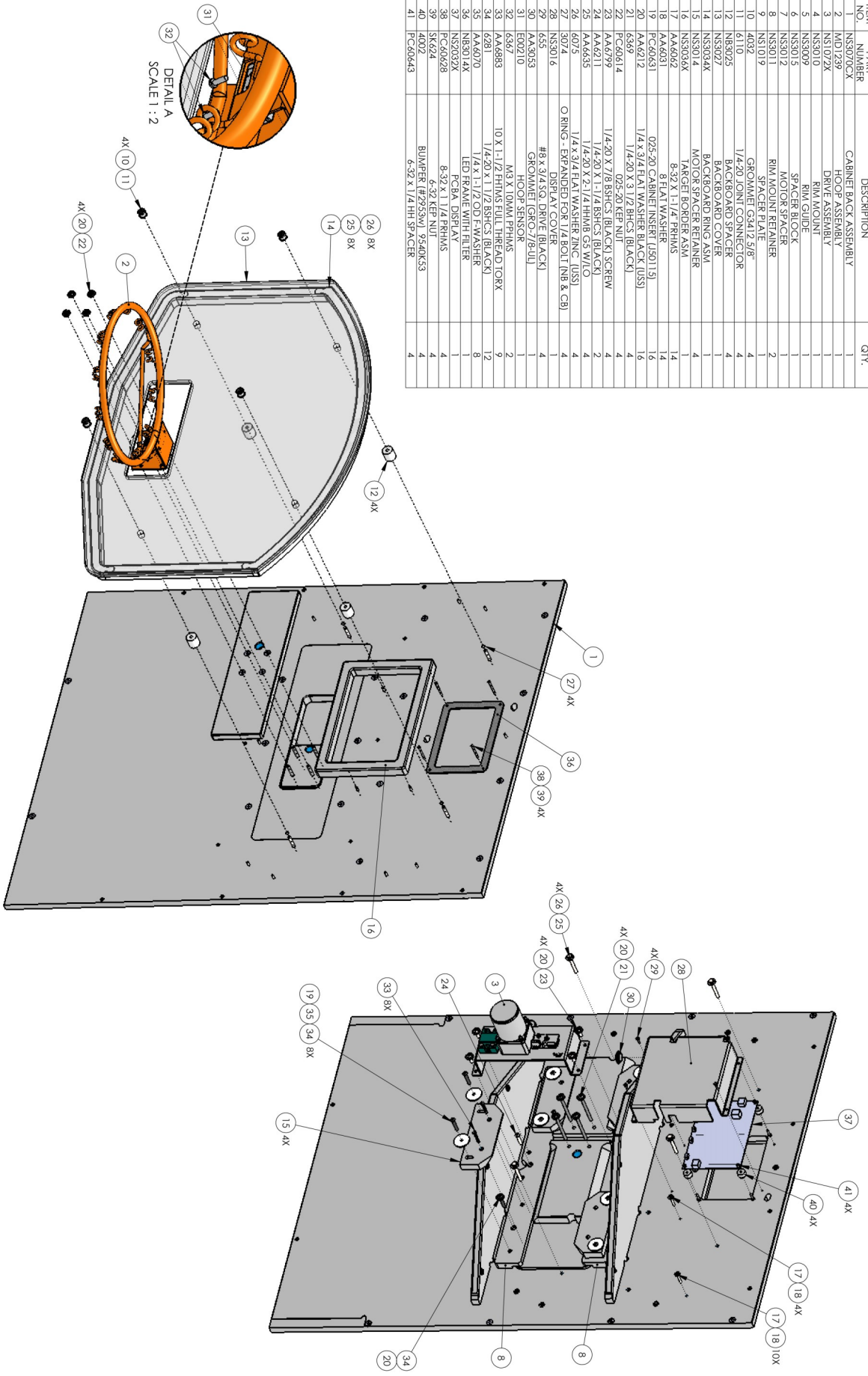

ITEM NO.	PART NUMBER	DESCRIPTION	QTY.
1	NS3030CX	CONTROL ASSY	1
2	NS7012M	CONTROL PANEL	1
3	AA0644	6-32 X 1/2"HH SPACER	12
4	FC60643	6-32 X 1/4"HH SPACER	28
5	NS1008	PODIUM FRONT PANEL	1
6	NS3035	PODIUM ACCESS PANEL	1
7	NS6012	1/4 X 3/4" (A) W/SHR BUCK (USS)	11
8	6200	1/4 X 3/4" (A) BUSH (BLACK)	2
9	6211	1/4 X 3/4" (A) LEG BUSH	2
10	NS3008	SPEAKER SPACER	2
11	SK624	6-32 KEP NUT	8
12	NS3030	LEFT SIDE LED COVER	1
13	DD2007X	ASY POWER SUPPLY	1
14	MR2218	BUTTON MED ROUND MULTIPLAYER	1
15	ML2032X	PCBA (DISPLA, RED LED DIGITS)	1
16	CR2233X	PCBA (DISPLA)	1
17	BB2004	BUTTON MED RD ORANGE BB LEGEND	1
18	BB1009	CASH BOX ENCLOSURE	1
19	HF1007	TICKET DISPENSER	1
20	HF1008	CASH BOX DOOR	1
21	HF1008	COIN DOOR (DBV AND DUAL MECH) ASSY	1
22	HH5005CL	TICKET DISPENSER	1
23	1024	TICKET BIN (DOUBLE)	1
24	RS3023	SUBWOFFER SPACER	1
25	DJ2007	SPEAKER 6" WOOFER 4 OHM	1
26	6555	#8 X 5/8 SQ. DRIVE (SILVER)	10
27	655	#8 X 3/4 SQ. DRIVE (BLACK)	20
28	5014	7/8" CAMLOCK	2
29	AA6004	8-32 X 1/2" PHMS (BLACK)	11
30	AA6072	8-32 NYLOCK NUT	10
31	6004G	8-32 KEP NUT	10
32	6244	8-32 X 7/8" PEMA STUD	4
33	AA6913	8-32 X 1-1/2" BHCS SECURITY (BLACK)	8
34	NS3031	RIGHT SIDE LED COVER	1
35	9073A194	8-32 X 1/2" PHMS	1
36	E02007	SPEAKER (4/8 OHM ROUND)	2
37	AA6490	8-32 X 6.5 PHMS	2
38	GF2010	POWER SUPPLY (MEAN WELL)	1
39	BA1016 Rev C	GADPT.SP.320 POWER SUPPLY BRKT	1
40	AA6713	6-32 X 1-1/2" FEM STUD	12
41	ZS3035	AUDIO AMP 21 CHANNEL	1
42	ZS3035	RELAY BOARD	1
43	WC1040	BRACKET (DOOR SWITCH/POD LATCH)	1
44	E00156	SWITCH	1
45	NS3034X	PCBA (MAIN)	1
46	NS3035X	PCBA FACE -SPEIGHT PROGRAM	1

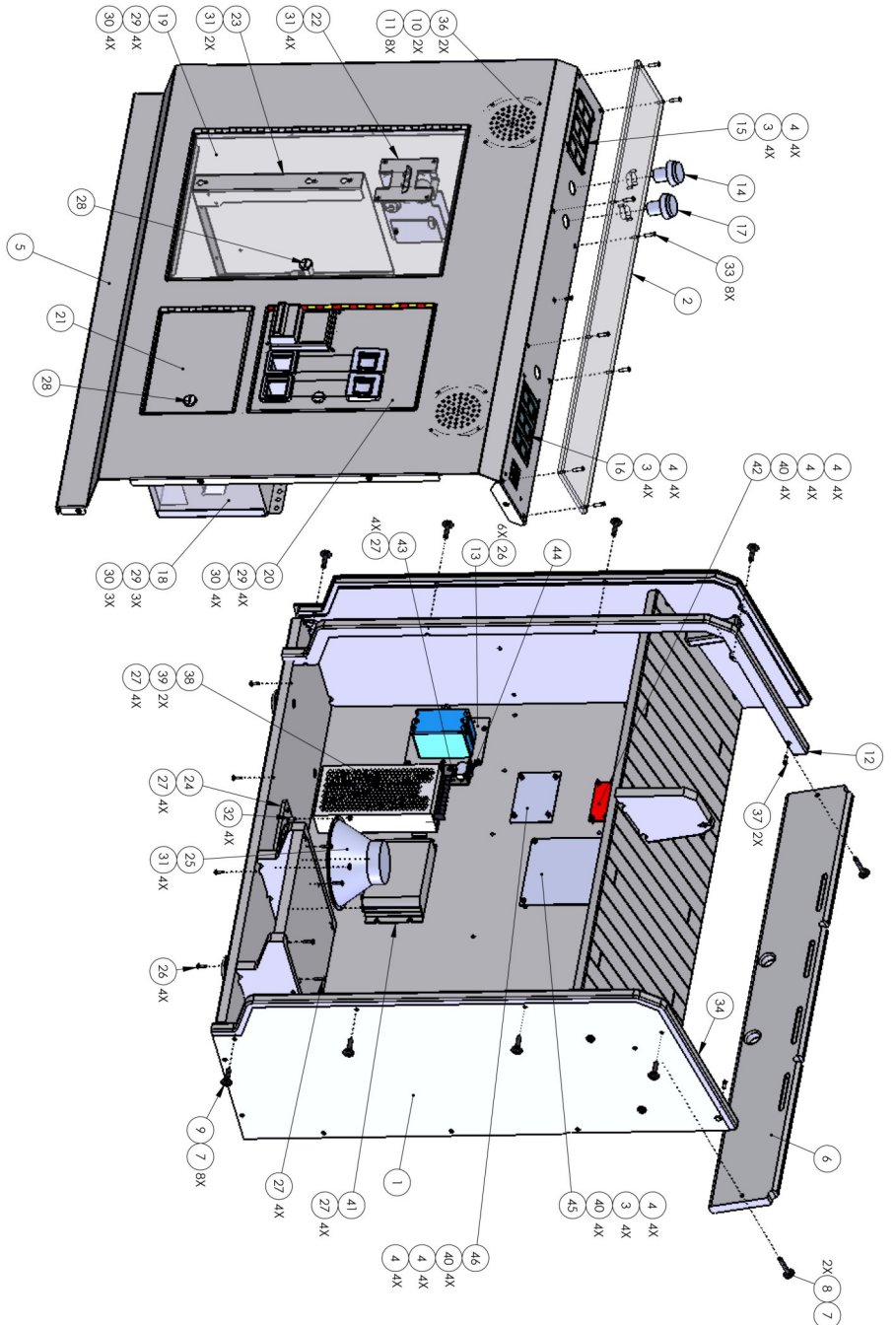

ITEM NO.	PART NUMBER	DESCRIPTION	QTY.
1	NS1050X	FRAME ASM	1
2	NS1010	CAGE SIDE	2
3	NS3071X	BACKBOARD ASSEMBLY	1
4	NS1058	FRONT LEG WELDMENT	2
5	NS3064	FLOOR PANEL	2
6	NS1013X	ASY (TOP CAGE)	1
7	NS1015	REBOUND CAGE	1
8	6444	1/4-20 X 1.5/32 JOINT CONNECTOR	8
9	6799	1/4-20 X 7/8 BSHCS (BLACK)	8
10	AA6220	1/4-20 X 1.3/4 BSHCS (BLACK)	8
11	NS1022	BALL GATE ASSY	1
12	NS1017	ACTUATOR COVER	1
13	6555	#8 X 5/8 SQ. DRIVE (SILVER)	44
14	NS1027	WIRE COVER	2
15	6110	1/4-20 JOINT CONNECTOR	16
16	6107	1/4-20 X 0.75 STUD	8
17	AA6799	1/4-20 X 7/8 BSHCS (BLACK) SCREW	6
18	AA6053	1/4 LOCK WASHER	12
19	PC-60631	025-20 CABINET INSERT (J50115)	4
20	AA6177	8-32 X 1 PHHMS	5
21	6061	8-32 CAB INSERT (J-50111)	7
22	SK613	#8 STAR WASHER	7
23	AA6211	1/4-20 X 1-1/4 BSHCS (BLACK)	4
24	752015X	ASY (LINEAR ACTUATOR)	1
25	NS1021	MOTOR COVER	1
26	NS1036X	DECAL (NBA LOGO REAR)	1
27	PW1052	ACTUATOR ASSEMBLY	1
28	AA6973	SPRING, STOP(Z) (BW HAN	2
29	AA6281	1/4 X 4 DOWEL PIN SS	1
30	AA69846	1/4-20 X 1-1/2 BSHCS (BLACK BOLT)	4
31	AA6971	1/4-20 NYLOCK NUT BLACK ZINC	4
32	AA6031	1/4 X 1-1/2 CLEVIS PIN	1
33	AA6155	8 FLAT WASHER	4
34	PC-60622	8-32 X 7/8' PHHMS	2
36	PC-60622	1/4-20 X 1 BSHCS BLK	8

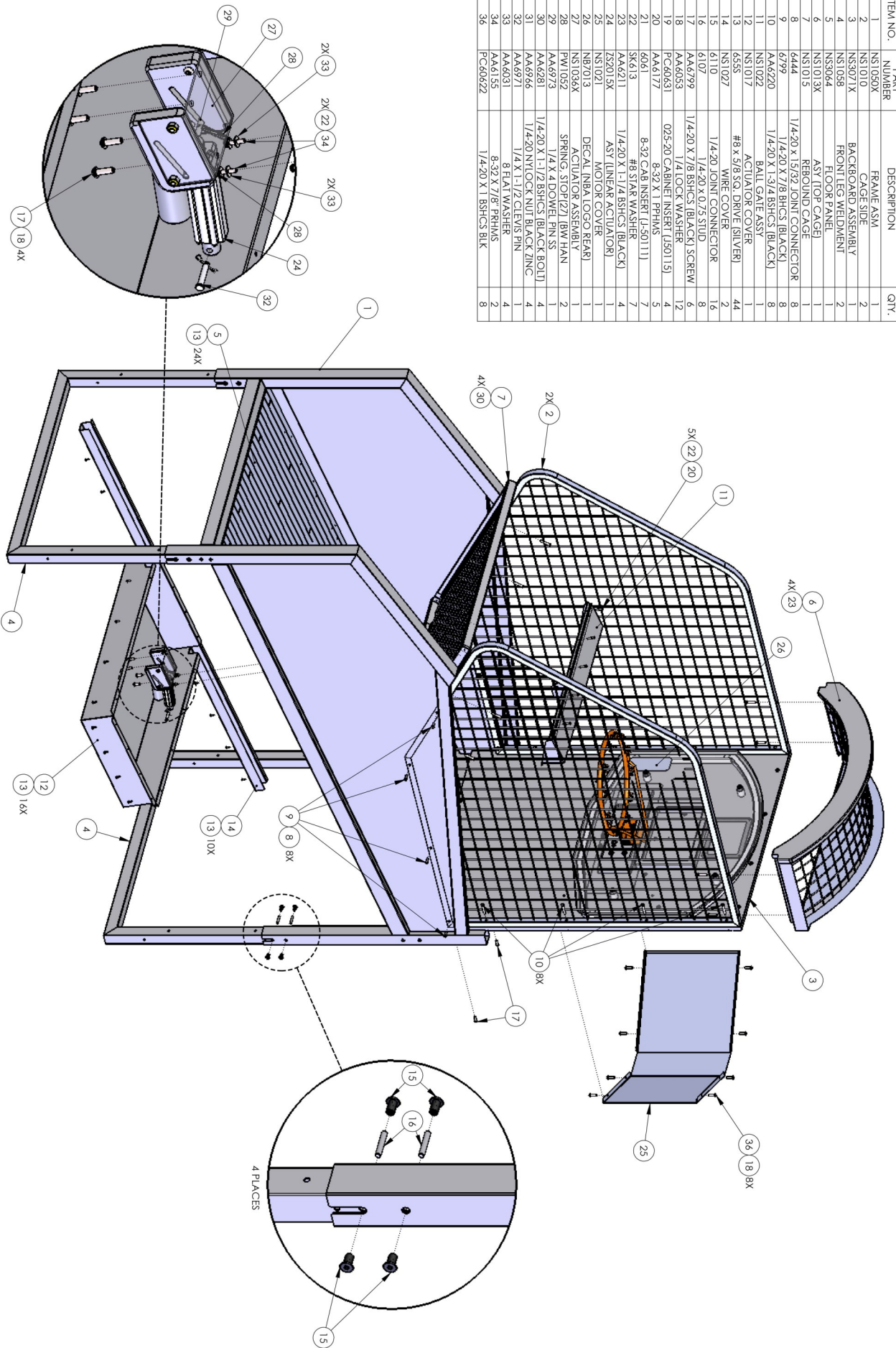

Hardware list for Marquee install.

4X(A) **AA6094**
1/4-20 X 3 HHMB W/ THREAD LOCK

6X(B) **AA6917**
1/4-20 X 2 BSHCS .6 THREAD

14X(C) **AA6212**
1/4 X 3/4 FLAT WASHER BLACK ZINC (USS)

4X(D) **AA6966**
1/4-20 NYLOCK NUT BLACK ZINC

4X(E) **NS3004**
MQ MOUNT SPACER

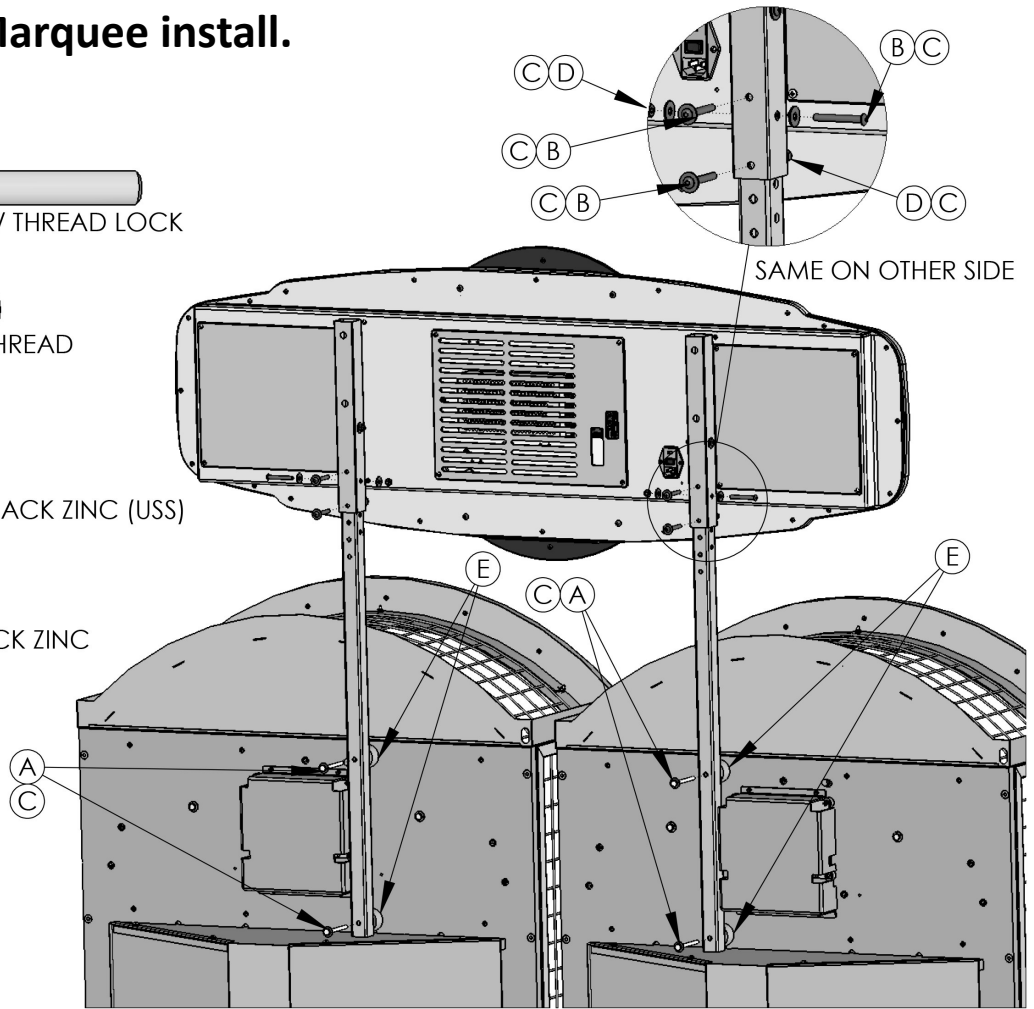

Suggested Spares

NS3050X ASY FRONT CABINET

Item number	Description
AA5014	LOCK (7/8 CAMLOCK) ,45
BA2063LX	HARNESS (MONITOR SUPPLY AC)
BB2004	BUTTON MED RD ORANGE BB LEG-END
CB2233X	PCBA (DISPLAY)
DJ2007	SPEAKER 6" WOOFER 4 OHM
E02007	SPEAKER (4/8 OHM ROUND)
E2034XX	PCBA (BRAIN BOARD W/ 8716 FLAS
GF2010	POWER SUPPLY +12VDC 29A (ROHS)
ML2032X	PCBA (DISPLAY) RED LED DIGITS
NB2218	BUTTON MED ROUND (MULTIPLAYER)
NS2007X	ASY (POWER MOD 6 AMP)
NS2033X	PCBA FACE
NS2034X	PCBA MAIN
NS2050HX	HARNESS (MAIN)
NS2051LX	HARNESS (PROGRAMMING BUT-TONS)
NS2064LX	HARNESS (AMP POWER 12V)
NS2084LX	HARNESS (AUDIO)
ZS2006	AUDIO AMP 2.1 CHANNEL
ZS2035X	PCBA (RELAY)

NS1072X ASY (MOTOR MOUNT)

Item number	Description
E02111	RELAY SOLID STATE (SVDA/3V10)
NS1077	DRIVE ROD
NS2008A	GEARBOX
NS2061LX	HARNESS (AC RELAY)
NS2063LX	HARNESS (HOOP SENSOR DC POWER)
NS7048	REFLECTOR
PE2009SX	ASY (MOTOR 110V) SPG
WS2039NSX	HPCB (HOOP SENSOR)

NS3064X ASY REAR CABINET

Item number	Description
E00210NSX	HARNESS (HOOP SENSOR)
E00724NSAX	ASY (LED STRIP LARGE RGB 52 CUTS
E00724NSBX	ASY (LED STRIP LARGE RGB 21 CUTS
MD1239-P200	HOOP (ORANGE)
NB3001P	BASKETBALL 8.5" (HARDENED PU L
NB3025	BACKBOARD STANDOFF (REV A)
NS1072X	ASY (MOTOR MOUNT)
NS2032X	PCBA DISPLAY
NS3070	BACKBOARD
NS7048	REFLECTOR
PW1052	SPRING, STOP(27) (BW HAN
SC4002	BUMPER (SMALL ROUND WITH IN- NER
SF3008	CHAIN NET 10208
ZS2015X	ASY (LINEAR ACTUATOR)

NS1013X ASY (TOP CAGE)

Item number	Description
E00788NSAX	ASY (LED STRIP LARGE WHITE DUAL

Item number Description

LC3002	FILTER (2 x 2-1/2 RED)
ML3001	DISPLAY FILTER SCORE (CONTROL
NB3009	FILTER DISPLAY Rev.1

MISC Items

Item number	Description
NS2008A	Gearbox only
NB3002P	Leather balls
NS1077	Hoop Drive Arm



WARRANTY POLICY

I.C.E. Inc warrants all components in new machines to be free of defects in materials and workmanship for the period listed below:

- 180 days on Main PCB's, Computers & Motors
- 1 year on all LCD monitor panels
- 90 days on all other electronic and mechanical components
- 30 days on all I.C.E. repairs and parts purchases

I.C.E. Inc shall not be obligated to furnish a warranty request under the following conditions:

- Equipment or parts have failed through normal wear and tear
- Equipment has been subjected to unwarranted stress, abuse or neglect
- Equipment has been damaged as a result of arbitrary repair/modification

Products will only be covered under warranty by obtaining an I.C.E. authorized RMA #. To obtain an RMA # please provide I.C.E. tech support with the game serial # or original I.C.E. invoice # and a detailed description of the failure or fault symptoms.

I.C.E. Inc will assume no liability whatsoever for costs associated with labor or travel time to replace defective parts. All defective warranty covered components will be replaced with new or factory refurbished components equal to OEM specifications.

I.C.E. Inc will cover domestic UPS ground, or comparable shipping costs during the warranty period. International or expedited shipments are available for an additional charge. To obtain credit defective parts must be returned to I.C.E. Inc, at the customer's expense, within 30 days. After 30 days a 15% re-stocking fee will apply to all returns.

ICE distributors are independent, privately owned and operated. In their judgment, they may sell parts and/or accessories other than those manufactured by I.C.E. Inc. We cannot be responsible for the quality, suitability or safety of any non-I.C.E. part or modification (including labor) that is performed by such a distributor.

Innovative Concepts in Entertainment
10123 Main St.

Clarence, NY 14031

Phone #: (716) - 759 – 0360

Fax #: (716) – 759 – 0884

www.icegame.com